

SUMMACUT[®] SERIES



User's Manual
Rev 007

FCC Notice

The SummaCut cutters have been tested and found to comply with the limits for a Class A digital device, pursuant to part 15 of the FCC Rules. These limits are designed to provide reasonable protection against harmful interference when the equipment is operated in a commercial environment. This cutter generates, uses, and can radiate radio frequency energy and, if not installed and used in accordance with the instruction manual, may cause harmful interference to radio communications. Operation of this equipment in a residential area is likely to cause harmful interference in which case the user will be required to correct the interference at his own expense.

Caution!

Changes or modifications not expressly approved by Summa, who is responsible for FCC compliance, could void the user's authority to operate this equipment.

DOC Notice

The SummaCut cutters comply with the CAN ICES-003 Class A limits for Information Technology Equipment.

Notice

Summa reserves the right to modify the information contained in this User Manual at any time without prior notice. Unauthorized copying, modification, distribution or display are prohibited. All rights reserved.

Waste Electrical and Electronic Equipment (WEEE) Directive

Directive 2012/19/EU of the European Parliament and of the Council

The symbol (right) is shown on this product. It indicates that the product should not be placed in municipal waste but should be disposed of separately.

Electrical and electronic equipment can contain materials, which are hazardous to the environment and human health, and therefore should be disposed of at a designated waste facility or returned to your retailer for appropriate recycling to take place.

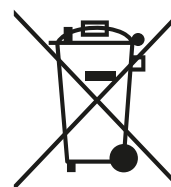

be
the

If you wish to dispose of this product and the product still functions, please consider recycling/reusing it by donating it to a charity shop, selling it or exchange parts of it with your retailer.

Registering Your Cutter

Please register your cutter on the following link:

<http://www.summa.be/registration.html>

Contact Information

All inquiries, comments or suggestions concerning this and other Summa manuals should be directed to:

Summa, nv
Rochesterlaan 6
B-8470 GISTEL
Belgium

Web Site
www.summa.eu

Welcome

Congratulations on your purchase of the new cutter!

The SummaCut cutters are made for sign makers, demanding only the very best cutting quality.

SummaCut is Summa's most popular and affordable line of vinyl cutters. Their characteristics and performance match those of the most excellent cutters. They offer tracking accuracy, speed and features not found in other affordably-priced cutters.

Summa engineers know there's not a more important vinyl cutter feature than tracking. That's why every cutter we build starts with our exclusive and patented MicroSprocket™ grit roller. The unrivalled media tracking system guarantees the highest precision on cuts up to 8 meters long. So, there's no need to monitor whilst the machine performs a cutting job, not even during long cutting jobs.









SummaCut now offers the unmatched Optical POSitioning Sensor OPOS X. The automated contour alignment system OPOS stands for OPTical POSitioning System. The OPOS X sensor technology senses marks on a wide range of materials. Some of our latest features include a fully automated workflow with barcode reading, enabling you to contour-cut multiple jobs without any user intervention. Another feature is while using multiple sheets with repeating graphics, the OPOS sensor will start looking for marks immediately after a new sheet is loaded.

This manual is a reference guide for installing and operating the SummaCut Series cutters.

Minimum revisions needed for this manual:
Firmware cutter: 032 (MD9985)
Cutter Control version 5.5.10 (installed from Cutter Tools version 2.9.0)
USB driver: version 6.4

Table of Contents

1	Setup	1-1
1.1	Unpacking the Cutter	1-1
1.1.1	Removing the packaging from the cutter	1-1
1.1.2	Setting up the machine with a stand	1-2
1.1.3	Setting up the machine without a stand	1-4
1.2	SummaCut Cutter Components	1-5
1.2.1	The Cutter as viewed from the front	1-5
1.2.2	The Cutter as viewed from the back	1-7
1.3	Safety, Ideal Operating Environment, Connecting to the Mains	1-9
1.3.1	Safety	1-9
1.3.1.1	General	1-9
1.3.1.2	Symbols used in the manual	1-9
1.3.1.3	Safety precautions	1-10
1.3.2	Operating environment	1-10
1.4	Connecting the Cutter to the Mains	1-11
1.4.1	Grounding (“Earthing”)	1-11
1.4.2	Operating voltage	1-11
1.4.3	Powering-on the cutter	1-12
1.5	Connecting the Cutter to a Computer	1-13
1.5.1	USB connection	1-13
1.5.1.1	Connecting the SummaCut cutter to a PC, using a USB cable	1-13
1.5.1.2	Connecting the SummaCut cutter to a Mac, using a USB cable	1-14
1.5.2	Ethernet connection	1-15
1.5.3	RS-232 Connection	1-17
1.6	Loading Media	1-18
1.6.1	Pinch roller positioning	1-18
1.6.2	Loading media	1-19
1.6.3	Media load procedure	1-22
1.7	Tool Installation	1-25
1.7.1	Knife installation	1-25
1.7.2	Pen installation	1-28

2	Basic Operation	2-1
2.1	LCD and control panel	2-1
2.1.1	Control Panel	2-2
2.1.1.1	The menu key 	2-2
2.1.1.2	The exit key 	2-2
2.1.1.3	The enter key 	2-2
2.1.1.4	The test key 	2-2
2.1.1.5	The jogging keys  ,  ,  and 	2-2
2.2	How to Set Tool Parameters.....	2-3
2.2.1	Setting the tool type	2-3
2.2.2	Changing the tool pressure	2-4
2.2.3	Changing the drag knife offset	2-5
2.3	How to Set the Cutting Speed.....	2-6
2.4	How to Change the User (Quick Parameter Change).....	2-7
2.5	How to Make Sure the Sign Has the Correct Size	2-8
3	OPOS (Optical POSitioning).....	3-1
3.1	Introduction	3-1
3.2	Basic OPOS operation	3-1
3.2.1	OPOS calibration	3-2
3.2.2	Media calibration	3-3
3.3	Detailed OPOS Operation.....	3-5
3.3.1	Printing the graphic.....	3-5
3.3.2	Loading the graphic into the cutter	3-6
3.3.3	Registering the marks	3-6
3.3.4	OPOS panelling.....	3-7
3.4	Automating Tasks with OPOS	3-9
3.4.1	OPOS origin	3-10
3.4.1.1	In combination with OPOS X mode	3-10
3.4.1.2	In combination with OPOS XY mode.....	3-10
3.4.2	Cutting multiple copies of a graphic on the same roll.....	3-12
3.4.3	Cutting the same graphic on multiple media sheets	3-12
3.4.4	OPOS Barcode	3-13
3.5	Cutting through	3-15
3.5.1	Procedure	3-15
3.5.2	Practical tips.....	3-18
3.5.2.1	Physical knife depth	3-18
3.5.2.2	Values of the FlexCut parameters	3-19
3.5.2.1	Material without a backing.....	3-20

4	Detailed Operation	4-1
4.1	Introduction	4-1
4.2	Main Menu	4-1
4.2.1	Pressure	4-2
4.2.2	Knife offset	4-2
4.2.3	Pouncing Gap	4-2
4.2.4	User	4-2
4.2.5	FlexCut	4-2
4.2.6	Tool	4-2
4.2.7	System Setup	4-2
4.3	System Setup	4-3
4.3.1	Action menu	4-3
4.3.1.1	Opos barcode	4-3
4.3.1.2	Confidence test	4-3
4.3.1.3	Load	4-3
4.3.1.4	Extended Load	4-4
4.3.1.5	Replot	4-4
4.3.1.6	Reset	4-4
4.3.1.7	Media alignment	4-4
4.3.2	Setting menu	4-5
4.3.2.1	Velocity	4-5
4.3.2.2	Overcut	4-5
4.3.2.3	OptiCut	4-5
4.3.2.4	TurboCut	4-6
4.3.2.5	Panels	4-6
4.3.3	Calibration menu	4-7
4.3.3.1	Cal. Media	4-7
4.3.3.2	Cal. OPOS	4-7
4.3.3.3	Calibrate XY	4-7
4.3.4	Configuration menu	4-8
4.3.4.1	IP config	4-9
4.3.4.2	Language	4-9
4.3.4.3	Menu Units	4-9
4.3.4.4	FW version	4-9
4.3.4.5	Copy User	4-9
4.3.4.6	OPOS Parameters	4-9
4.3.4.7	Factory Def	4-9
4.3.4.8	USB Class	4-10
4.3.4.9	Autoload	4-10
4.3.4.10	Recut offset	4-10
4.3.4.11	Media Sensor	4-11
4.3.4.12	Alignment Mode	4-11

5	Maintenance and Cleaning.....	5-1
5.1	Introduction.....	5-1
5.1.1	Cleaning the drive system.....	5-1
5.1.2	Cleaning the media sensor.....	5-2
5.1.3	Cleaning the Y-Guide Rail.....	5-2
5.1.4	Changing the fuse.....	5-3
6	Specs and General Information.....	6-1
6.1	Models.....	6-1
6.2	Features List.....	6-1
6.2.1	Hardware.....	6-1
6.2.2	Interface.....	6-1
6.2.3	Functionality.....	6-1
6.2.4	Software.....	6-2
6.2.5	Cutter accessories and consumables delivered with cutter.....	6-2
6.3	Technical Specification.....	6-3
6.3.1	Machine dimensions.....	6-3
6.3.2	Shipping dimensions.....	6-3
6.3.3	Media.....	6-4
6.3.4	Performance.....	6-6
6.3.5	Interface.....	6-6
6.3.6	Firmware.....	6-6
6.3.7	Environmental.....	6-7
6.3.8	Electrical.....	6-7
6.3.9	Certifications.....	6-8
6.4	Cutter accessories and consumables part numbers.....	6-9

List of Figures

1-1 SummaCut cutter fully boxed	1-1
1-2 Contents of box stand	1-2
1-3 Contents of box basket	1-2
1-4 Mounting feet.....	1-2
1-5 Mounting horizontal panel.....	1-3
1-6 Mounting the 4 casters.....	1-3
1-7 Mounting the cutter on the stand	1-3
1-8 Installing the basket	1-3
1-9 Position of the cutter on a table.....	1-4
1-10 SummaCut cutter front view.....	1-5
1-11 SummaCut cutter rear view	1-7
1-12 Properly grounded connection.....	1-11
1-13 Media is loaded and the cutter is ready.....	1-12
1-14 Cutter is ready and no media is loaded	1-12
1-15 Position pinch roller	1-18
1-16 Pinch roller lever.....	1-19
1-17 Media flanges	1-19
1-18 Position media flange cutter.....	1-19
1-19 Feeding roll media without using the flanges	1-20
1-20 Media position.....	1-20
1-21 Pinch roller lever.....	1-21
1-22 Removing the drag knife holder from the clamp.....	1-25
1-23 Removing the knife from the standard drag knife holder	1-25
1-24 Knife length adjustment.....	1-26
1-25 Dual clamp drag head.....	1-26
1-26 Knife pressure test pattern	1-27
1-27 Knife is chosen tool	1-28
1-28 Pen is chosen tool	1-28
2-1 Control panel.....	2-1
2-2 Correct knife offset pattern.....	2-5
2-3 Length calibration pattern	2-9
3-1 Position media from multiple sheet.....	3-13
3-2 OPOS barcode job loaded	3-14
3-3 FlexCut principle	3-15
3-4 Combined contour cut and cutting through	3-17
3-5 Knife depth setting normal cutting.....	3-18
3-6 Knife depth setting cutting through	3-18
4-1 Main menu	4-1
4-2 setting menu.....	4-3
4-3 Settings menu	4-5
4-4 Overcut	4-5
4-5 Settings menu.....	4-7
4-6 Configuration menu.....	4-8
5-1 Placement of vinyl strip	5-1
5-2 Media sensor SummaCut cutters	5-2
5-3 Sliding surfaces on Y=guide rail.....	5-2
5-4 Power entry module.....	5-3

1 Setup

1.1 Unpacking the Cutter



NOTE: Save the shipping box and any other packaging items in case the cutter needs to be shipped. Do not ship the cutter without first completely repacking it in its original packaging. A document explaining how to repackage is available.



WARNING: For safety reason no fewer than two people should be involved in unpacking the cutter.

Before unpacking the cutter, make sure that there is enough space to assemble the stand and to set the cutter aside to insert the stand screws.

1.1.1 Removing the packaging from the cutter

1. Remove the straps and the staples and open the lid of the box.
2. The cutter is packed in foil. The models D120, D140 and D160 are delivered with the stand and basket under in the box. The accessories are located at the side in a separate box. Check first whether everything is present.
3. Do not throw away the packaging. Shipping it without the original box voids any warranty.



FIG 1-1
SUMMACUT CUTTER FULLY BOXED



NOTE: The basket is optional for the D140 FX.

1.1.2 Setting up the machine with a stand

1. Verify that the stand and basket come with all the accessories.
The box containing the stand should contain following:

- a. 2 legs
- b. 2 feet
- c. 1 horizontal panel
- d. A bag of 4 casters, screws and other accessories to mount the stand



FIG 1-2
CONTENTS OF BOX STAND

2. The box containing the basket should contain following:
 - a. A total of 7 tubes for the media basket
 - b. A linen media basket
 - c. A bag of accessories to mount the basket



FIG 1-3
CONTENTS OF BOX BASKET

3. Mount a foot on each leg. Make sure that, in case the legs are orientated the same way, the long end is pointing in one direction on one leg and in the other direction on the other leg.



FIG 1-4
MOUNTING FEET

4. Mount the horizontal panel. Make sure the hollow side is orientated to the same side as the long ends of the feet (this would then be the rear).



FIG 1-5
MOUNTING HORIZONTAL PANEL

5. Turn the stand upside down and mount the 4 casters (put the nut in the casters first, then use the 12 mm wrench).



FIG 1-6
MOUNTING THE 4 CASTERS

6. Turn the stand the right way up again, put the machine on the stand and secure with 4 screws.



FIG 1-7
MOUNTING THE CUTTER ON THE STAND

7. Mount the basket. Make sure the long tubes are used at the rear. Put a saddle clip to keep tubes in their place.



FIG 1-8
INSTALLING THE BASKET

1.1.3 Setting up the machine without a stand

The smaller models are equipped with an extra media guide. In order not to damage this part, special attention is requested when putting a machine on a surface. This media guide should always be situated over an edge.



FIG 1-9
POSITION OF THE CUTTER ON A TABLE

1.2 SummaCut Cutter Components

1.2.1 The Cutter as viewed from the front

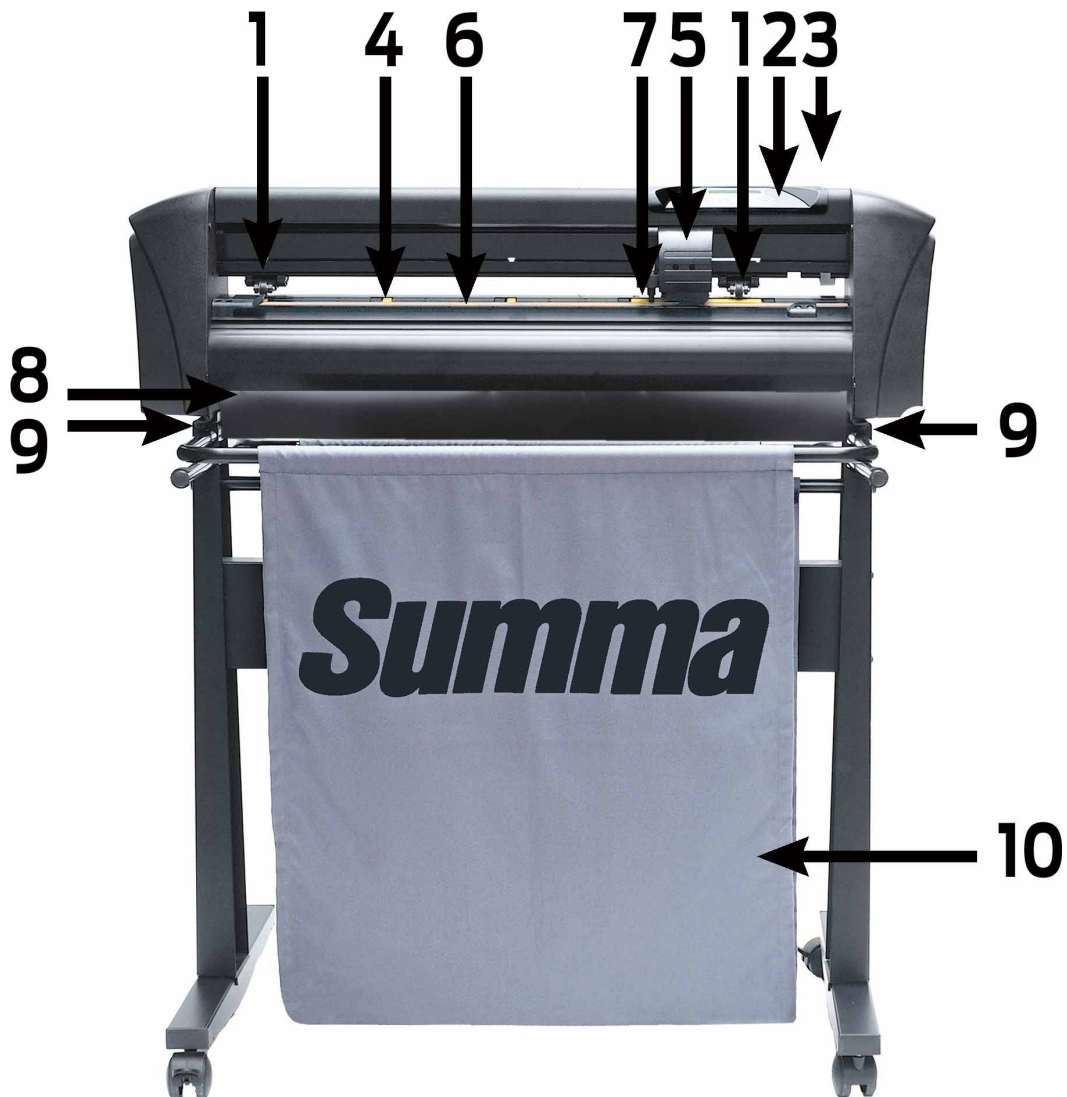

FIG 1-10
SUMMACUT CUTTER FRONT VIEW

- 1. Pinch rollers:** The pinch rollers clamp the media to the drive system to ensure accurate tracking. The D120 has one and the D140 and D160 have two extra pinch rollers to ensure that wide media stays flat in the middle. The extra rollers in the middle can be enabled or disabled.
- 2. Keypad:** All cutter activity can be initiated from the keypad. The LCD displays information about the cutter's current status and/or actions that need to be taken.
- 3. Pinch roller lever:** This lever is used to raise and lower the pinch rollers for media loading.
- 4. Media drive sleeves:** The media drive sleeves only move the media when the pinch rollers are in the "down" position. The larger the model, the more small sleeves.
- 5. Tool carriage:** The tool carriage is the mount for the knife holder, pen or pouncing tool. It also holds the Optical POSitioning sensor (OPOS).

6. **Cutting strip:** A self-healing orange strip helps avoid any damage to the knife tip when no media has been loaded. Since cutting is done on the cutting strip, it is essential that the strip remains intact.
7. **Media sensor:** A media sensor behind the right sleeve is used to detect the end of the loaded media.
8. **Media guide:** Only available on smaller models. Prevents the media from slipping under the cutter when installed on a table.
9. **Screws to secure the cutter base:** Make sure all screws are secured at each side before the cutter is used.
10. **Media basket:** The stand and linen media basket come standard with all D120, D140 and D160 models (except model D140FX).

1.2.2 The Cutter as viewed from the back

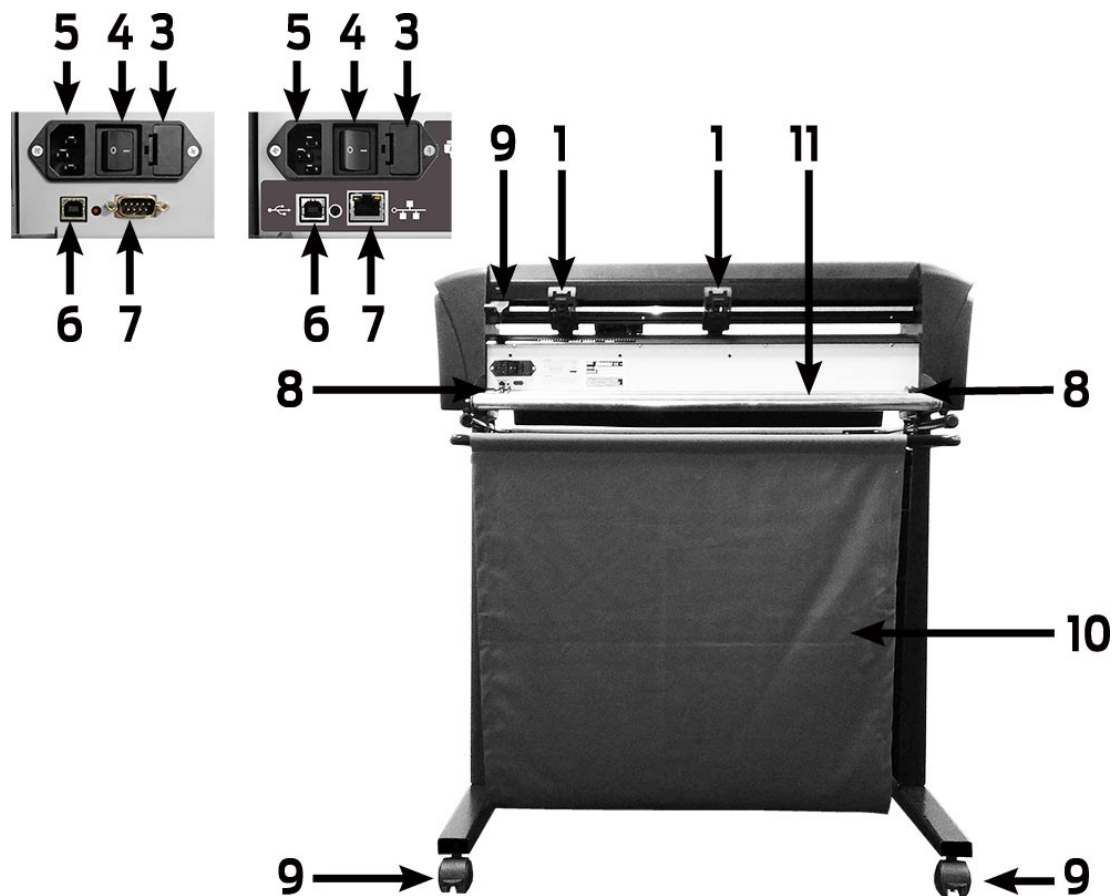

FIG 1-11
SUMMACUT CUTTER REAR VIEW

1. **Pinch rollers:** The pinch rollers clamp the media to the drive system to ensure accurate tracking. The D120 has one and the D140 and D160 have two extra pinch rollers to ensure that wide media stays flat in the middle. The extra rollers in the middle can be enabled or disabled.
2. **Pinch roller lever:** This lever is used to raise and lower the pinch rollers for media loading.
3. **The fuse box:** The fuse is located at the right side of the power entry module. Check the specification section to see which fuse is used in the SummaCut cutter.



WARNING: For continued protection against risk of fire, replace only with the same type and rating of fuse.

4. **Power On/Off switch:** This rocker switch, situated in the middle of the power entry module, sets the cutter's power to ON or OFF. To switch on the power, press the "I" side of the rocker switch. To switch off the power, press the "O" side of the rocker switch.
5. **AC power cord receptacle:** It is located at the left-hand side of the power entry module. The power-up procedure is explained in detail in section 0. Always use a power cord that was delivered with your cutter.

6. **USB port:** This interface is based on the standards specified in Universal Serial Bus Specifications Revision 1.1. It allows a high-speed bi-directional communication between the host computer and the cutter.
7. **Second communication port can be serial port or Ethernet dependent on the model:**
Serial DB-9P: This provides serial bi-directional communication between the cutter and a host computer.
Ethernet port RJ45: For connecting the cutter to the LAN.
8. **Roll media guide bushes:** The two flange guides serve to keep the media roll in place when media is pulled from the roll.
9. **Casters:** The casters on the stand are equipped with locking brakes. Once the cutter has been moved to its new location, press the brakes with your foot to lock the casters.
10. **Media basket:** The stand and linen media basket come as standard equipment with all 120, 140 and 160 SummaCut cutters (except model D140FX).
11. **Media support rollers:** Rotating support rollers for the media roll.

1.3 Safety, Ideal Operating Environment, Connecting to the Mains

1.3.1 Safety

1.3.1.1 General

The purpose of the user's manual is not only to explain the operating procedures of this machine, but it also provides the owner, users and operators with precaution procedures for safe and proper machine operation for its intended purpose.

All information in this manual must be read and understood before any attempt is made to operate the machine.

The manufacturer has no direct control over the machine operation and application. Proper safety practice is the sole responsibility of the owner, user and operator.

All instructions and safety warnings in this manual are based upon the use of this machine under proper operating conditions without alterations from the original design.

Any use of the cutter that is beyond the capabilities of the combination knife/material is considered as improper use and may result in injury and serious damage to the machine and will lead to loss of warranty.

1.3.1.2 Symbols used in the manual



Warning with dark (red) symbol: Refers to immediate threat that can cause serious injuries and effects on health and safety.



Warning with light (yellow) symbol: Refers to a dangerous situation that can cause injuries and serious damage to the machine.



Attention with dark (red) symbol: Refers to useful information to prevent damage to the equipment and prolong the service life of the machine.



Attention with light (yellow) symbol: Refers to useful tips to enhance the user-friendliness and make the work significantly easier.



Note: Can be considered as a general tip; something that is useful to know.

1.3.1.3 Safety precautions



WARNING: The SummaCut cutters use razor-sharp knives. Touching the knife with bare hands may cause injury. Do not touch the knives while the machine is cutting.



WARNING: There is a risk of injury from being caught or trapped in moving machine parts. Keep hands, hair, clothing and jewellery away from moving parts. Do not wear jewellery, loose clothing, scarves, open jackets or shirtsleeves.

The entire base plate should be considered as a dangerous area when the cutter is switched on and off. The tool carriage can move from the left to the right and the yellow media sleeves are sharp and can grab loose objects, clothing or body parts.

The cutter constantly measures the current through the motors. If the machine detects the current is too high, then the current will be cut off to the motors and a fatal error message will be displayed on the control panel.

Make sure to observe all the caution labels on the cutter.

1.3.2 Operating environment

Environmental conditions can significantly affect the machine's performance.

The environmental conditions of the machine (without media) are as follows:

Operating Temperature	15 to 35° C	59 to 95° F
Storage temperature	-30 to 70° C	-22 to 158° F
Relative humidity	35 - 75 %, non-condensing	35 - 75 %, non-condensing

It is possible that the environmental conditions of the used media are stricter than those of the machine itself. Please refer to the documentation about the used media.

Moreover, make sure that the media has had enough time to acclimatize.



NOTE: Keep the cutter away from direct sunlight or a strong indoor light source. The optical sensors in the machine may be affected, thus causing unexpected behaviour of the cutter.

1.4 Connecting the Cutter to the Mains

1.4.1 Grounding (“Earthing”)

WARNING: An insulated ground conductor must be installed as part of the branch circuit that supplies power to the wall outlet, connected to the cutter. The ground conductor must have the same size, insulation material and thickness as the grounded and ungrounded branch-circuit-supply-conductors, but the insulating seat should be green or green with yellow striping.



The ground conductor described above must be grounded at the electrical distribution board or, if power is supplied by a separate system, at the power supply transformer/motor generator set.

The wall sockets, into which the cutter is plugged-in, must be of the grounded type. The grounded conductors, serving the wall socket, must be properly connected to the ground.

For emergency access, the cutter should be installed near the socket-outlet for easy access.

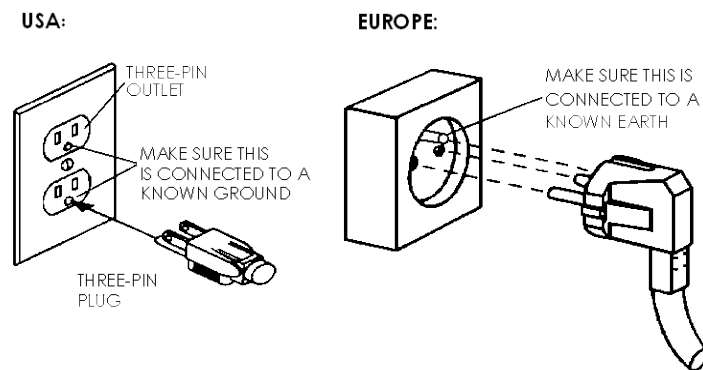

FIG 1-12
PROPERLY GROUNDED CONNECTION

1.4.2 Operating voltage



WARNING: Before changing the fuse, make sure that the cutter is completely disconnected from its power source.



WARNING: For continued protection against risk of fire, replace only with the same type and rating of fuse.

Fuse Rate: T2.0A, 250V SCHURTER SPT OR EQUIVALENT.

The power supply detects the line voltage and switches automatically between 110V and 230V.

1.4.3 Powering-on the cutter



WARNING: Make sure the power switch is turned off before connecting the power cord (the “0” side of the ON/OFF rocker switch should be pressed).



WARNING: Do not use the power cord if it is visibly damaged. Disconnect the power cord by pulling the **plug**, not the **cable**.



WARNING: Keep fingers and other body parts away from the cutting area. There are **hazardous moving parts**.

1. Plug the female end of the AC power cord into the receptacle, located in the power entry module on the cutter's rear panel.
2. Plug the male end of the AC power cord into a properly grounded wall socket.
3. Power on the cutter by pressing the “I” side of the ON/OFF rocker switch, located on the power entry module on the rear panel.
4. The touch screen will activate and the initialization process will begin. If media is loaded, then the cutter will check the size and load the media.



FIG 1-13
MEDIA IS LOADED AND THE CUTTER IS READY



FIG 1-14
CUTTER IS READY AND NO MEDIA IS LOADED

1.5 Connecting the Cutter to a Computer

The SummaCut cutters support Ethernet, bi-directional USB and RS-232 connectivity. Depending on the model, the connectivity can change. When both ports are connected at the same time, the port that receives the data first will remain active and the other port will be deactivated.

1.5.1 USB connection

The USB cable should be 5 meters (16 feet) or less in length. The connector on the cutter side of the cable should be USB series B 4-pin. The connector on the computer side of the cable should be USB A 4-pin.

1.5.1.1 Connecting the SummaCut cutter to a PC, using a USB cable



ATTENTION: When installing a cutter, make sure the user has administrative rights and UAC is deactivated or set it to its lowest level (not applicable for Windows XP or earlier versions).

1. Power-off the cutter.
2. Insert the CD into the computer's CD-ROM drive.
3. Choose to run Windows_autostart.
4. Choose the language and click on install USB driver. Wait for the driver to install.
5. Connect one end of the USB cable to a USB port on the computer.
6. Connect the other end of the USB cable to the USB port on the back of the cutter.
7. Power on the cutter (see section 0) and return to the computer.

The Found New Hardware Wizard should appear on the computer screen and install the USB driver.

8. Click "OK" and follow the instructions, provided by the Wizard.
9. Restart the computer.



ATTENTION: When connecting a cutter to a computer for the first time, using the USB cable, the computer will detect the cutter and install the USB driver if the setup program was run. If the setup program was not run prior to connection, then install the program while the cutter is connected and switched on. After the program has run, the computer will detect a new device and install the correct driver automatically.



NOTE: In order to connect more than one cutter to one computer, see the section on the USB class 0.



ATTENTION: It is recommended to always use the latest version of the driver. The CD is made this way it downloads the latest version automatically. If no internet connection is available, then it is possible that the driver on the CD is outdated.

1.5.1.2 Connecting the SummaCut cutter to a Mac, using a USB cable

➤ Mac OSX

Most recent cutting software does not need a driver installation when a computer is connected to the cutter. The software that controls the driver is built into the cutting software.

1.5.2 Ethernet connection

The Ethernet cable should be a shielded CAT6 Ethernet cable.

A couple of parameters need to be set when connecting a cutter to the Ethernet. It is best to ask the network administrator whether a static address is needed or if a DHCP server is used. If a static address is used ask for the address and the subnet mask.

- In case the DHCP server is used:

Just connect the cutter and write down the IP address to set up the cutting software.

Check the IP address in the communication menu:

1. Connect the Ethernet cable and power on the cutter (see section 1.4.3).

2. Press  .

'Knife Pressure' will appear on the LCD.

3. Press  .

'System Setup' will appear on the LCD.

4. Press  .

'Actions' will appear on the LCD.

5. Use  or  to scroll through the menu until 'Configuration' is reached, press  .

'IP Config' will appear on the LCD.

6. Press  .

'DHCP' will appear on the LCD.



NOTE: The default setting for the cutter is DHCP, if the settings is set to Static, then first set the parameter to use DHCP by pressing on the right arrow key and then on the enter key twice. Thereafter, reboot the cutter.

7. Press  .

'The IP address is shown on the screen.'

8. Write this down and use it to set up your software.

- Use static address:

The static address that you received will be used in the software to drive the cutter. It has also to be set in the cutter itself.



NOTE: It is recommended to use an static IP address.

1. Connect the Ethernet cable and power on the cutter (see section 1.4.3).

2. Press .



'Knife Pressure' will appear on the LCD.

3. Press .

'System Setup' will appear on the LCD.

4. Press .

'Actions' will appear on the LCD.

5. Use  or  to scroll through the menu until 'Configuration' is reached, press .

'IP Config' will appear on the LCD.

6. Press .





'DHCP' will appear on the LCD.





NOTE: The default setting for the cutter is DHCP. If the setting has already been changed to "STATIC" then leave it at that, otherwise change it to this value as described below.

7. Press .

'An IP address is shown on the screen.'

8. Press . Press  until the blinking cursor is above the first digit. Then use  or  to set the correct value. Press the  to jump to the next digit. Repeat this until the IP address is set correctly.

9. Then press  to jump to the subnet setting. Repeat the above procedure to set the subnet correct.

10. Then press  to leave the menu and reboot the cutter.

1.5.3 RS-232 Connection

The RS-232 cable should be 5 meters (16 feet) or less in length. The connectors on both sides are DB-9S type connectors. There is no need to install a device driver when connecting a cutter with an RS-232 connection.

The parameters of the RS-232 connection must be set in either the properties of the COM port in the device manager or in the cutting software program itself. Please refer to the manual for the cutting software on how to set the parameters for the RS-232 connection with the cutter.

Default settings of the RS-232 connection are listed in the table below.

Baud rate	9600
Data Bits	8
Parity	none
Stop Bits	2
Flow Control	Hardware or XON / XOFF

TABLE 1-1
DEFAULT RS-232 SETTINGS OF THE SUMMACUT CUTTER

1.6 Loading Media

The following procedures mainly apply to the use of roll media. If you are using sheets, there are two options:

For long sheets: roll up the sheet, so that the alignment is identical to the one of a roll.

For short sheets: the alignment is not so important. If the sheet is cut off perpendicularly, it can be aligned to the front border.

1.6.1 Pinch roller positioning

Proper movement of the media will only occur if the media is driven by the two outer pinch rollers, which are correctly located over two drive sleeves.

The pinch rollers are lowered or raised simultaneously by means of the pinch roller lever arm, located on the right-hand side of the cutter. The pinch rollers must be lifted to allow vinyl loading, during which the media is fed from the rear of the cutter to the front. When raised, the pinch rollers can be moved manually to the left or the right along the pinch roller shaft.



ATTENTION: Always make sure that the pinch rollers are fully raised before sliding them to the left or right.

Always hold the assembly at the side of the pinch roller to move it from left to right. Do not reposition the pinch roller by holding the assembly at the rear of the machine.

The pinch rollers **MUST** be positioned correctly and lowered onto the media before an automatic load sequence is initiated. Make sure all the pinch rollers are positioned above a drive sleeve. The outer left pinch roller should be positioned in one of the detents (click position), situated right under a white triangular label. The outer right pinch roller should be positioned somewhere over the long drive sleeve. Click positions are located at the edges of the sleeve (area marked with a white triangular label).

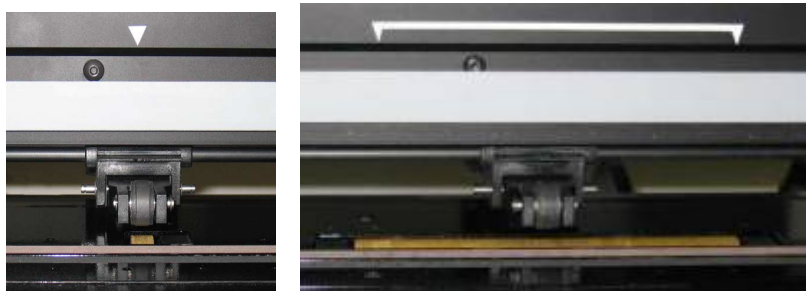

FIG 1-15
POSITION PINCH ROLLER



ATTENTION: Always leave the pinch rollers in the “up” position when the cutter is not in use. Leaving the pinch rollers in the “down” position for a long time will result in a flat spot in the pinch rollers, which will seriously [negatively] affect tracking performance and cutting quality.



NOTE: When the pinch rollers are raised during a job, the cutter will immediately stop and move the carriage to the right side.

1.6.2 Loading media

1. Raise the pinch rollers by means of the pinch roller lever arm, which is located at the right-hand side of the cutter, next to the touch panel.



FIG 1-16
PINCH ROLLER LEVER

2. Loosen the knobs on the two media flanges. The following illustration shows a loosened flange (1) and a tightened flange (2).



FIG 1-17
MEDIA FLANGES

3. Insert a loosened flange into one end of the media roll and tighten the knob. Verify that the flange is secure. Then do the same at the other side of the roll.
4. Place the flange-equipped roll on the media supply rollers. Set the flanges inside the groove of the flange guide. The flange guides can be moved laterally on the roller.



FIG 1-18
POSITION MEDIA FLANGE CUTTER



ATTENTION: If the flanges are not used (not recommended – tracking is not guaranteed), then make sure that the roll is situated between the two flange guides.

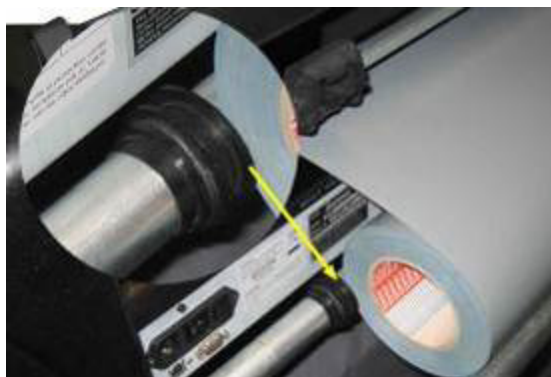

FIG 1-19
FEEDING ROLL MEDIA WITHOUT USING THE FLANGES

5. Start feeding the media from the rear of the machine. Pass the media underneath the pinch rollers towards the front of the machine.
6. Position the left media edge on the left most drive sleeve and check whether the right media edge is positioned over the long drive sleeve. Then position the left and right pinch rollers.

The pinch rollers should be positioned over the drive sleeves about 3 to 15 mm (0.1" to 0.6") away from the media's outer edges (1). Then pull on the media while holding the flange at the back, so the media is tight.



FIG 1-20
MEDIA POSITION

In circumstances where the above procedure does not work, because the media is too narrow to reach the long drive sleeve, try positioning the left media edge over the second left drive sleeve and position the right media edge somewhere over the long drive sleeve. Continue moving the left pinch roller towards the long drive sleeve until both pinch rollers are in their designated position and directly over the edges of the vinyl.

In all cases, both edges of the media must cover a drive sleeve. If this is not the case, reposition the roll of material to cover the drive sleeve.

7. Make sure the media follows a straight path from the roll of material. To accomplish this, slide the media roll and flange guides from the left to the right along the media support rollers.



WARNING: Keep fingers and other body parts away from the cutting area. There are hazardous moving parts.

8. Lower the pinch roller lever to press the media firmly against the drive sleeves. After one second the tool carriage automatically moves from the right to the left to sense the usable media width.



FIG 1-21
PINCH ROLLER LEVER



ATTENTION: It is not recommended to unroll the media manually from the roll. The cutter will unroll the media automatically during the load sequence.

9. The positioning and routing of sheet material is identical to that of roll media.
10. The cutter is now operational.

1.6.3 Media load procedure



WARNING: Do not place any objects in front of, or behind, the cutter that could interfere with cutter operation. Make sure the media is free to move forward and back. Keep hands, hair, clothing and jewelry away from moving parts.

While the cutter is activated, it will automatically start executing a minimal loading procedure as soon as the pinch rollers are lowered. The load procedure will also start when the cutter is switched on while media is already in the machine and the pinch rollers are in the “down” position (this is not recommended). Always keep the pinch rollers in the up position while the cutter is not being used.

The minimal loading procedure consists of:

- A media width measurement.
- Media is unwound over a length equal to the width measured between the outer two pinch rollers.
- A simultaneous 45° axial move of the drive drum (sleeves) and cutting head.

After that, the cutter is ready to receive files from the computer.

When receiving a job from the computer, the cutter will automatically pull the required media from the roll. It does this in steps and the length of the vinyl used is equal to a number of times the measured width of the media.

This load procedure is sufficient in most of the cases. However, there are some extra load features available.



ATTENTION: Tracking of longer signs can only be guaranteed when the full load procedure is performed!





WARNING: Each keystroke can initiate an internal test or movement of the head or media. Keep fingers and other body parts away from the cutting area. There are hazardous moving parts.

➤ **Changing origin.**

1. Press  ,  ,  and  to change the origin.

The media will move to the new origin. Values will appear on the LCD. The X value is the distance from the original origin; the Y value is the maximum cutting width.

2. Press  to toggle the Y value between the maximum cutting width and distance from the original origin. Press  to toggle between the maximum cutting length and the distance from the original origin.

The X and/or Y value will toggle.

3. Press  if the desired origin is reached.

The cutter comes online and is ready to receive data from the computer.

4. Or press  to cancel.

The cutter will move to its original origin and come online.

➤ **Extended load.**

The function extended load makes it possible to define the limits of the Y axis so that the cutter can cut outside the pinch rollers. Media needs to be loaded before this function can be used.

1. Press .

The tool pressure will appear on screen.

2. Press .



'System Setup' will appear on the LCD.

3. Press .



'Actions' will appear on the LCD.

4. Press .

'OPOS Barcode' will appear on the LCD.

5. Press  or  until 'Extended Load' appears on screen and press .



'Origin' will appear on the LCD.

6. Press  or  to define the new limit at the right (origin).

The head will move to its new origin.

7. Press  .

'Size' will appear on the LCD.

8. Press  or  to define the new limit at the left.

9. Press  .



ATTENTION: Tracking is not guaranteed when using this mode.

1.7 Tool Installation



WARNING: The SummaCut cutters use razor-sharp knives. To avoid serious injury, be careful when installing, removing or handling the knife!

1.7.1 Knife installation

A knife has been pre-installed in the cutter.

For safety reasons, the knife depth has been set to zero. Simply turn out the knife (see fig 1-22 yellow arrow clockwise) to start cutting. Below is the complete description of the knife removal and knife installation.

➤ *Removing the drag knife*

1. Loosen the head clamp screw (1), swing the clamp arm back and remove the knife holder from the clamp (2).

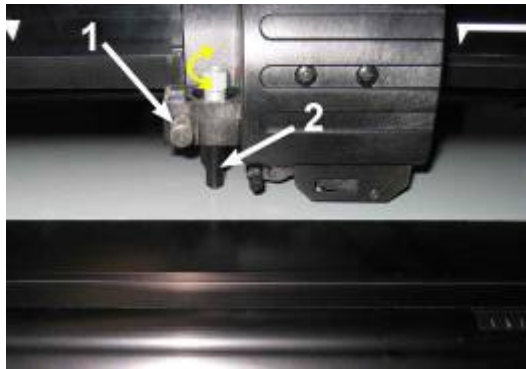

FIG 1-22
REMOVING THE DRAG KNIFE HOLDER FROM THE CLAMP

2. Turn the knurled adjustment knob (3) clockwise to push the knife (4) out of the holder (5).



FIG 1-23
REMOVING THE KNIFE FROM THE STANDARD DRAG KNIFE HOLDER

3. Carefully pull the knife from the holder.

➤ *Installing the drag knife*

1. Remove the aluminum piece from the plastic knife holder (5) by turning the knurled adjustment knob (3) counter clockwise until the aluminum piece comes out of the holder.
2. Insert the conical, non-cutting end of the knife into the opening in the narrow end of the holder. Gently push the knife all the way in.
3. Turn the holder upside down and tap it lightly on a solid surface to ensure the knife is completely inserted.
4. Slowly turn the knurled knob clockwise until the tip of the blade extends the distance required for the desired cutting media (t), as shown in the figure below.

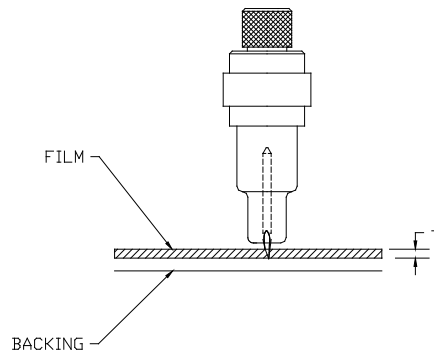

FIG 1-24
KNIFE LENGTH ADJUSTMENT

5. Insert the knife holder into the head clamp and push it all the way down (1).



FIG 1-25
DUAL CLAMP DRAG HEAD

6. Tighten the clamp screw (2).

➤ **Setting knife depth and pressure:**

(Media must be loaded in the cutter before the knife pressure can be tested).





WARNING: Each keystroke can initiate an internal test or movement of the head or media. Keep fingers and other body parts away from the cutting area. There are hazardous moving parts.

1. Press .

Knife Pressure will appear on the LCD.

2. Press .

Current knife pressure will appear on the LCD.

3. Press  or  to change the knife pressure.

The value will change

1. Press  to perform the internal knife pressure test.

2. Press  to confirm the chosen knife pressure.

3. Press  to leave the pressure unchanged.

Once  is pressed, the current knife pressure value will be automatically set to the new value and the cutter will cut the knife pressure test pattern.

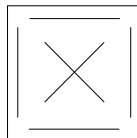



FIG 1-26
KNIFE PRESSURE TEST PATTERN

Peel out the rectangle and inspect the media backing.

The knife depth is set correctly when the test pattern cuts completely through the vinyl, the vinyl is removed and the blade tip visibly scratched the front side of the media backing. The blade should never cut through the backing; just slightly scratch the silicon coating and first few fibres of the backing material.

Because the knife pressure setting depends on the thickness and type of media to be cut, adjusting the knife pressure will require some practice. In general, the knife depth must be increased when using thicker types of vinyl and decreased when using thinner types of vinyl.

4. Press  twice to leave the knife pressure menu.



ATTENTION: After setting the cutting depth and/or the knife pressure, perform a thorough visual check of the knife blade, protruding from the knife holder and test the cutting results on a scrap of vinyl media.



CAUTION: Do not operate the cutter if the knife blade cuts through the media backing, as this will seriously damage the cutter's rubber cutting strip and the knife.



CAUTION: For most vinyl cutting operations, the knife blade tip will be barely visible at the bottom of the knife tool. If the knife blade tip is clearly visible, then the cutting depth must be readjusted. To prevent damage to the cutter, check the depth of the knife blade tip and the quality of the cut each time you load a different type of vinyl into the cutter.

1.7.2 Pen installation

The SummaCut cutters can also be operated with a kind of plotter pen. After replacing the knife with a pen, the cutter can be used as a plotter in order to draw draft plots of new or existing designs on paper.

1. Loosen the head clamp screw and remove the tool from the clamp.
2. Install the pen in the clamp and tighten the clamp screw.
3. The change of tool can either be done on the control panel, with Summa Cutter Control (PC only) or with the cutting software.

Selecting pen operation disables the knife offset correction, and changes the pressure to “pen pressure.”



ATTENTION: The information on the LCD shows the currently selected tool by the cutter. Make sure the cutter's tool setting matches the actual tool in use.

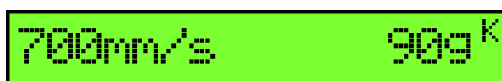

FIG 1-27
KNIFE IS CHOSEN TOOL



FIG 1-28
PEN IS CHOSEN TOOL

2 Basic Operation

2.1 LCD and control panel

The liquid crystal display (LCD) contains one line of 16 characters. The LCD provides cutter status information during operations and displays menu options for the configuration of the cutter.



FIG 2-1
CONTROL PANEL

The liquid crystal display (LCD) contains one line of 16 characters. The LCD provides cutter status information during operations and displays menu options for the configuration of the cutter.

The various menu and submenu items are always presented in a loop, which means that, when the last menu or submenu item is displayed, pressing the appropriate key will automatically take you back to the first item of the same menu or submenu.



NOTE: A parameter or parameter value, preceded by an asterisk (*), is the current selected parameter or parameter value. If a menu is left with a value on the LCD, which is not preceded by an asterisk, then this will not be the saved value.



WARNING: Each keystroke can initiate an internal test or movement of the head or media. Keep fingers and other body parts away from the cutting area. There are hazardous moving parts.

2.1.1 Control Panel

2.1.1.1 The menu key



The **MENU** key is used to reach the most common menu items of the cutter quickly. A last menu item in the row gives access to a submenu, which gives access to all the other functions of the cutter (see section 2.3).

2.1.1.2 The exit key



The **EXIT** key (cancel key) cancels the current operation.



NOTE: Pressing this key when the cutter is cutting stops the current job.

2.1.1.3 The enter key



The **ENTER** Key (confirm key) confirms a selected menu or a changed menu item. As long as this key is not pressed, a changed value of a menu item will not be saved internally and will be lost if the menu is left.

2.1.1.4 The test key







If there is a certain test routine in a submenu, this can be activated to start the test. This key also starts the barcode procedure.

2.1.1.5 The jogging keys



The use of the jogging keys varies according to the operation in progress.

For example, when working with different submenus, the  or  jogging key is used to select the next or previous submenu.

When in a submenu, the values can be changed by pressing  or  .
When the cutter is in standard operation, the origin can be changed by pressing either one of the jogging keys.

2.2 How to Set Tool Parameters

The SummaCut cutters can work with a knife, pen or pouncing tool (optional). Once a tool has been changed, the tool parameters must be reset or checked. All the different tools have one parameter name in common: the pressure. Each tool has also its specific parameters.

Tool parameters can be changed by either changing them in the current user, or simply by changing the user (see section 0).



ATTENTION: The SummaCut cutters will only perform according to specifications if a genuine Summa knife, pen or pouncing tool is installed. Do not replace the standard knife, pen or pouncing tool with products from other manufacturers.





WARNING: Each keystroke can initiate an internal test or movement of the head or media. Keep fingers and other body parts away from the cutting area. There are hazardous moving parts.

2.2.1 Setting the tool type

1. Power on the cutter.

2. Press .

'Knife pressure' will appear on the LCD.

3. Use  or  to scroll through the menu until 'Tool' is reached. Press .

Current selected tool will appear on screen.

4. Press  or  to change the tool.

The tool will change on the LCD.

5. Press  to confirm.

An asterisk will appear before the tool, indicating it is now the selected tool.

6. Press  twice to leave the menu.

If the tool type was changed, then the cutter will prompt the user to install the new tool.

2.2.2 Changing the tool pressure



1. Power on the cutter, load media, and mount the tool (see section 1).

2. Press  .



'Knife pressure' will appear on the LCD.

3. Press  .

Current pressure will appear on the LCD.

4. Press  or  to change the knife pressure.

The value will change

1. Press  to perform the internal knife pressure test (see section 1.7.1).
2. Press  to confirm the chosen knife pressure.
3. Press  to leave the pressure unchanged.

2.2.3 Changing the drag knife offset

A very important parameter for a drag knife is the offset. The offset is the distance between the knife centre and the knife tip.



NOTE: The knife offset should be set each time the knife is changed and should be checked if the knife shows signs of wear.



NOTE: A typical knife offset for Summa knives is between 0.41 and 0.45 for standard knives, between 0.9 and 0.97 for sandblast knives and between 0.49 and 0.52 for the 60 degrees knife.



NOTE: Sandblast knives should be used when the material, that needs to be cut, is thicker than 0.25 mm.

Changing knife offset:

1. Power on the cutter, load the media and mount the tool (see section 1).

2. Press  .



"Knife pressure" will appear on the LCD.

3. Use  or  to scroll through the menu until 'knife offset' is reached, press  .

The current offset will appear on the LCD.

4. Press  or  to change the knife offset.

The value will change

1. Press  to perform the internal knife offset test.
2. Press  to confirm the chosen knife offset.
3. Press  to leave the offset unchanged.

When the knife offset is set correctly, the test pattern looks like this:

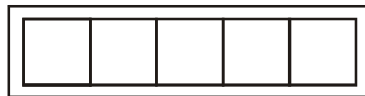
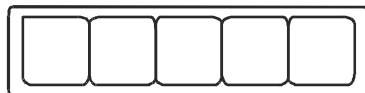
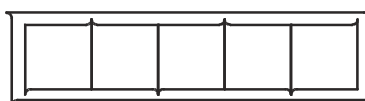

FIG 2-2
CORRECT KNIFE OFFSET PATTERN

When the knife offset is too low, the test pattern looks like this:



When the knife offset is too high, the test pattern looks like this:



2.3 How to Set the Cutting Speed

The actual speed at which the tool moves is determined by 4 different parameters. Speed (and acceleration) while the tool is down; speed (and acceleration) while the tool is up. These 4 parameters have been bundled in one parameter to enable to change the speed fast and easy.

This overall parameter is called "velocity" and represents the speed the cutter uses when the tool is down. If velocity is raised or lowered, the other parameters are also raised or lowered accordingly. The parameters can be changed individually but only with the program Summa Cutter Control.

There is one fixed speed: the speed at which the cutter pulls the media from the roll. This speed is fixed at 200 mm/s (8ips).

Setting the cutting speed:

1. Power on the cutter.

2. Press  .
'Knife pressure' will appear on the LCD.



3. Press  .
'System Setup' will appear on the LCD.

4. Press  .
'Actions' will appear on the LCD.

5. Press  .
'Settings' will appear on the LCD.

6. Press  .
'Velocity' will appear on the LCD.

7. Press  .
'Current set velocity will appear on the LCD.

8. Press  or  to change the velocity.
The velocity will change on the LCD.

9. Press  to confirm.
An asterisk will appear before the velocity, indicating it is now the selected velocity.

10. Press  twice to leave the menu.

2.4 How to Change the User (Quick Parameter Change)

The SummaCut cutters include 4 user configurations, all of which consist of the same parameters. Each configuration can have unique parameter settings. This allows the cutter to be quickly and easily reconfigured for different types of jobs or media.





NOTE: Factory default values for the different users are all set the same.

Changing the User Configuration:

1. Power on the cutter.

2. Press .

“Knife pressure” will appear on the LCD.

3. Use  or  to scroll through the menu until ‘User’ is reached. Press .

The current selected user will appear on the LCD.

4. Press  or  to change the user.

The value will change on screen, the asterisk will disappear.

5. Press  to confirm.

An asterisk will appear before the user, indicating it is now the selected one.

6. Press  twice to leave the menu.

2.5 How to Make Sure the Sign Has the Correct Size (Length Calibration)

The SummaCut cutters are friction-feed machines. This means the cutting length depends on the thickness of the material.

The cutters have been calibrated in the factory for standard 2-mil cast or 3-mil calendared vinyl. Each user (the SummaCut has a total of 4) can hold a different calibration factor.

This is very helpful for multi-coloured signs. It ensures that the parts in different colours match up, even if different types of vinyl media are used.













ATTENTION: For standard use, it is not necessary to calibrate the machine. With standard vinyl the accuracy is within 0.2%. However, if high accuracy between different vinyl or colours is needed, then calibration is necessary.

Calibrating the media (Length calibration):

1. Power on the cutter, load the media, and mount the knife (see section 1).



NOTE: The wider and longer the loaded media, the more accurate the calibration will be. Use a piece of vinyl of maximum width and a length that is approximately 1.5 times the width.

2. Press  .
'Knife pressure' will appear on the LCD.
3. Press  .
'System Setup' will appear on the LCD.
4. Press  .
'Actions' will appear on the LCD.
5. Use  or  to scroll through the menu until 'Calibrations' is reached, press  .
'Cal. Media' will appear on the LCD.
6. Press  .
7. Use  or  to scroll through the menu until 'Cal Length' is reached, press  .





The cutter will reload the media and perform the length calibration test. Take out the media and measure the length of the cut line with a ruler (measuring device). The length that needs to be entered is the distance between line 1 and line 2, as shown in the figure below.



FIG 2-3
LENGTH CALIBRATION PATTERN







NOTE: The cutter will only be as accurate as the accuracy of the calibration itself. If the ruler (measuring device) is inaccurate, then re-calibrating may worsen the cutter's accuracy. The accuracy of the calibration will be reflected directly in the cuts. Set the cutter to Metric to do the calibration. It is more accurate than the English unit system (see section 0).

8. Use , ,  and  to change the value on the LCD to the measured length of the distance between the two lines down the length of the vinyl roll.

The value will change on the LCD.

9. Press  to confirm.

The value for the Y axis will appear on the LCD.

10. Use , ,  and  to change the value on the LCD to the measured length of the distance between the two lines down the width of the vinyl roll.

11. Press  to confirm.

12. Press  twice to leave the menu.

3 OPOS (Optical POSitioning)

3.1 Introduction

Contour cutting is made possible by the highly accurate SummaCut Optical Positioning System (OPOS).

The OPOS sensor, which is mounted underneath the tool carriage, registers printed squares that are placed around the graphic. Because of this registration process, OPOS can determine the exact position of the printed graphic.

The sensor drops automatically while registering the marks and rises again after completing this task. The improved sensor can read virtually any kind of media-mark combination.

3.2 Basic OPOS operation

Many versions of cutting software have the built-in capability to make contour cutting user-friendly and automatic. Please refer to the user's manual that came with your software or contact your software dealer for specifics.

In general, contour cutting includes the following steps:

- Create a graphic and cut lines.
- Print the graphic (lamine, if necessary).
- Load the media and register the marks.
- Cut the graphic.

To ensure OPOS is working accurately, two calibrations are necessary: the OPOS calibration and the media calibration. The OPOS calibration is the calibration of the distance between the knife tip and the sensor. The media calibration “teaches” the cutter the reflection levels of the mark colour and the media colour.



NOTE: Although the OPOS sensor has been calibrated in the factory, Summa recommends doing a test to determine how well the factory-set parameters work with the materials you are using. If the accuracy is not what is expected, then do the OPOS calibration. Also refer to the section about detailed OPOS operation (section 0) for extra tips on defining and cutting contours.

3.2.1 OPOS calibration

1. Switch the cutter on and load black vinyl with white backing.



ATTENTION: Black vinyl with white backing **MUST** be used when calibrating OPOS. The media calibration setting must be set to the default value.

2. Set the head's origin above a clean, blank part of the vinyl.

3. Press .



'Knife pressure' will appear on the LCD.

4. Press .



'System Setup' will appear on the LCD.

5. Press .

'Actions' will appear on the LCD.

6. Use  or  to scroll through the menu until 'Calibrations' is reached, press .

'Cal. Media' will appear on the LCD.

7. Use  or  to scroll through the menu until 'Cal. OPOS' is reached, press .

The cutter will cut out a square measuring approximately 9.5x9.5 mm and move the square forward. "Weed Rectangle" will appear on the display.

8. Carefully weed the square, making sure the edges stay intact. Press .

OPOS will read the edges of the square and calibrate itself accordingly.



NOTE: In order to keep the accuracy of the OPOS sensor as high as possible, do this calibration each time the knife is been replaced.

3.2.2 Media calibration

Media calibration ensures that the sensor is able to recognize the marks. OPOS is calibrated at the factory to work on a wide range of media. However, certain media -- such as those with a high gloss -- may not work with the default settings. Before working with such materials, perform a media calibration test. This test will alter OPOS's sensitivity so that it will read the marks with greater reliability.

Print a square measuring at least 4x4 cm on the media that will be used. Be sure to use the same ink as the one that will be used when creating the registration marks.



ATTENTION: It is not recommended to do a media calibration for OPOS. If the media calibration is done and results didn't improve, set the media calibration value again to the default setting: 30 (the procedure explains this at a later stage).

Executing the media calibration:

1. Turn on the cutter and load the vinyl with the printed square.

2. Press  .



'Knife pressure' will appear on the LCD.

3. Press  .

'System Setup' will appear on the LCD.

4. Press  .

'Actions' will appear on the LCD.

5. Use  or  to scroll through the menu until 'Calibrations' is reached, press  .





'Cal. Media' will appear on the LCD.

6. Press  .

'Measure' will appear on the LCD.





The cutter allows the user to choose to either measure the media or to fill in a previously recorded value.



NOTE: If a combination of media colour – mark colour has already been calibrated and recorded, press  and then  . Now use  and  to enter this value directly, without having to re-measure it. Press  to confirm.





7. Press .

The cutter will lower the sensor. On the display, the message "put the sensor on the white area" will appear.

8. Use , ,  and  to manoeuvre the knife on top of a white area (the area should be at least 3 by 3 cm or 1" by 1").

9. Press  to confirm.

The cutter will make a circular movement while it measures the reflection of the media. It will briefly display the measured values and display the message "put sensor on black area."

10. Use , ,  and  to manoeuvre the knife on top of a black area (approximately in the middle and slightly to the bottom right).

11. Press  to confirm.

The cutter will make a circular movement while it measures the reflection of the mark colour. It will briefly display the measured values and will then show a value that is characteristic for this media colour – mark colour combination. Store this value for future reference.



ATTENTION: An error message may appear if the sensor is not able to differentiate between black and white. Make sure the test has been performed correctly. If OPOS is not able to sense the marks, one of the manual alignment methods (see 0.) must be used.

3.3 Detailed OPOS Operation

3.3.1 Printing the graphic

1. Print the graphic and its marks with a printer (scale = 100%). When printing on a roll, make sure that the graphic's Origin mark coincides with the media's origin (1).

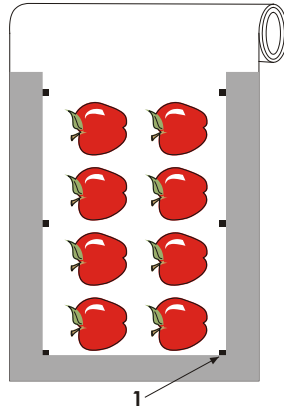

2. Make sure there is *at least* one cm (0.4in) margin on each side of the graphic (2). A 2 cm (0.8in) margin is preferable. There must also be a front margin of 1 cm (3).

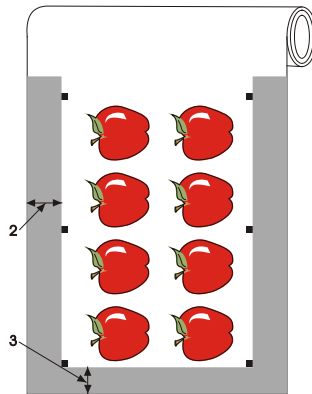

3. Leave a margin of at least 4 cm (1.6in), following the print when using sheets or when cutting the print from a roll (4).

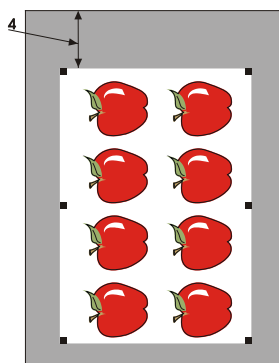

3.3.2 Loading the graphic into the cutter

Load the printout into the cutter as described in section 1.6. Make sure the mark, indicating the origin, is situated at the bottom right corner of the cutter.

3.3.3 Registering the marks

The OPOS parameters are variables that define the distance, size, and number of marks. These parameters are needed so the cutter can align the cut lines to the printed job. Most cutting software sets these parameters automatically and even starts the special load procedure.

If the software does not do this, initiate the loading sequence from the cutter's touch panel:

1. Power on the cutter and load the media.

2. Press  .

'Knife pressure' will appear on screen.

3. Press  .

'System Setup' will appear on the LCD.

4. Press  .

'Actions' will appear on the LCD.

5. Press  .

'OPOS Barcode' will appear on the LCD.

6. Press  and press  .

'Media Alignment' will appear on the LCD.

7. Press  .

A message prompting the user to set the knife above the first mark will scroll across the LCD.

8. Use  ,  ,  and  to do so and press  .

The cutter will reload the media, check if the loaded length and read the marks.



NOTE: If a mark cannot be read, the user will be given the option to re-position the knife (sensor) or to abort.



NOTE: If an error occurs or the cutter cannot read the marks after three attempts, the following message will be displayed: "Marks could not be sensed, press  to continue."

3.3.4 OPOS panelling

With this option, the job can be divided into panels in order to avoid moving the media unnecessarily back and forth. When OPOS panelling is activated, all cut data will be cut in panels. The size of the panel will be the distance between the OPOS marks in the X-axis.

OPOS Panels can be set to OFF, ON (2marks) or ON (4marks). When set to ON (2 marks), the cutter will only load 2 marks in the X-direction when loading OPOS and read the marks (4 in total for the first panel). The following panels will then be cut after reading the marks at the end of that panel (so 2 for each following panel). When set to ON (4 marks), the last marks of the previous panel are re-read. This improves the connection between the panels.



NOTE: Do not use software panelling when using OPOS panelling.

Activating OPOS panelling:

1. Power on the cutter.

2. Press .



'Knife Pressure' will appear on the LCD.

3. Press .



'System Setup' will appear on the LCD.

4. Press .



'Actions' will appear on the LCD.

5. Use  or  to scroll through the menu until 'Configuration' is reached, press .

6. *'IP Config' will appear on the LCD.*



7. Use  or  to scroll through the menu until 'OPOS Parameters' is reached, press .

'Sheet Mode' will appear on the LCD.

8. Use  or  to scroll through the menu until 'Panels' is reached, press .

The value of the chosen parameter will appear on the LCD.

9. Press  or  to change the value to 'ON'.
'ON' will appear on the LCD.

10. Press  and three times  .

3.4 Automating Tasks with OPOS

During normal OPOS jobs the user only needs to set the tool above the first mark to start the job. OPOS allows the user to automate certain tasks, thus reducing user intervention and production time. There are several types of automation.

Automatic start of the OPOS job

This is controlled by the parameter OPOS origin. A combination of this parameter setting and/or a special origin setting during loading of the media can ensure that the user doesn't need to set the tool above the first mark to start an OPOS job.

Multiple copies of the same job

When cutting multiple graphics, the user only needs to manoeuvre the OPOS sensor above the Origin mark of the first graphic. Cutting subsequent graphics does not require additional user input.

There are two multiple job situations where OPOS can be used:

- a. When cutting multiple (copies of a) graphic(s) on the same media roll.
- b. When cutting the same graphic on multiple media sheets.

Most automated tasks are organized from within the cutting software. However, when the same graphic contour needs to be cut out, the automatic tasks may also involve some manual manipulation.

Before using the automating features, note the amount of your cutter's RAM. If the cutter's RAM is *greater* than the job's file size, then the automating features can be used. If the cutter's RAM is *less* than the job's file size, the automating features should not be used.

Unattended contour cutting (roll to roll)

A special barcode can be printed together with the job. This barcode can then be used to access the correct cutting data, so the cutter can cut one job after another without user intervention.

3.4.1 OPOS origin

The parameter OPOS origin is created to automate the start of the OPOS procedure. This parameter has 4 settings. The usage of this parameter depends on the chosen OPOS mode.

This parameter can be found in the system sub menu OPOS parameters (see section 0).

If the OPOS is OPOS barcode or OPOS Sheet, then this parameter has no effect.

The useful combinations are mentioned in the table below.

	OPOS X	OPOS XY
Mark	'Indicate Mark'	'Indicate Mark'
XY-correction line	-	'Indicate Line'
Current Position	'Current Position'	'Current Position'
Centre of Media	-	'Centre of media'

3.4.1.1 In combination with OPOS X mode

OPOS Origin is set to 'Mark'.

This is the default setting. Upon receiving an OPOS job from the computer, the cutter will prompt the user to set the tool above the first mark and press Apply. The cutter will then start searching for the OPOS mark around that position.

OPOS Origin is set to 'Current position'.

Upon receiving an OPOS job from the computer, the cutter will immediately start looking for the mark when it gets an OPOS job from the computer, without waiting for the user to move the tool. Therefore, the user will have to set the tool above the first mark while loading the material.

If OPOS origin is set to either 'XY-correction line' or 'Centre of media', the cutter will react as if the parameter was set to 'indicate mark'.

3.4.1.2 In combination with OPOS XY mode

OPOS Origin is set to 'Mark'.

This is the default setting. Upon receiving an OPOS job from the computer, the cutter will prompt the user to set the tool above the first mark and press Apply. The cutter will then start searching for the OPOS mark around that position.

OPOS origin is set to 'Indicate line'

Upon receiving an OPOS job from the computer, the cutter will prompt the user to set the tool under the OPOS XY line and press Apply. The cutter will then start searching for the OPOS XY line by slowly moving forward the media. Once it has found it, it will follow this line to the right until it finds the location of the first mark and then it will start searching for the actual first mark.

OPOS origin is set to 'Current Position'

Upon receiving an OPOS job from the computer, the cutter will immediately start searching for the OPOS XY line by slowly moving forward the media. Once it has found it, it will follow this line to the right until it finds the location of the first mark and then start searching for the actual first mark. Therefore, the user will need to set the origin under the OPOS XY line, immediately after having loaded the media.

This setting has been created for jobs, which are left aligned and differ a lot in size. The origin/tool can then be set to the left of the media under the OPOS XY line, so that the origin mark can be found, even if it is situated far away from the right side of the media.

OPOS origin is set to 'Centre of media'

Upon receiving an OPOS job from the computer, the cutter first sets the OPOS sensor in the middle of the media. Then it will start searching for the OPOS XY line by slowly moving forward the media. Once it has found the XY line, it will follow it to the right until it finds the location of the first mark and then it will start searching for the actual first mark.

This setting has been created for jobs on a roll where the width of each job is at least half the width of the media (this is usually the case; otherwise there would be a lot of wasted media). This method is slightly slower than the previous method.

3.4.2 Cutting multiple copies of a graphic on the same roll

If the same graphic design has been printed on a roll with equal distance between these different graphics, then this feature can be used.

This way of automating is very software dependable. Usually the necessary parameters need to be set in the software itself. In rare cases, the distance between jobs needs to be set in the cutter itself. The only possible way to do this is to use Summa Cutter Control.

3.4.3 Cutting the same graphic on multiple media sheets

This feature can be used if the same graphic design has been printed on multiple sheets.



ATTENTION: The sheets should approximately the same size and the graphics on them should be oriented and positioned the same way.

First, load the media and check whether the parameters of the OPOS marks are set correctly.

Cutting the same graphic on multiple media sheets:

1. Power on the cutter.

2. Press .



'Knife Pressure' will appear on the LCD.

3. Press .



'System Setup' will appear on the LCD.

4. Press .

'Actions' will appear on the LCD.

5. Use  or  to scroll through the menu until 'Configuration' is reached, press .



6. *'IP Config' will appear on the LCD.*

7. Use  or  to scroll through the menu until 'OPOS Parameters' is reached, press .

'Sheet Mode' will appear on the LCD.

8. Press  to confirm.

The value of the chosen parameter will appear on the LCD.

9. Press  or  to change the value to 'ON'.

'ON' will appear on the LCD.

10. Press  to confirm.

An asterisk will appear before ON, indicating it is now the selected setting.

11. Press  twice to leave the menu.

12. Register the marks and cut the first contour as described in sections 3.3.4 and 3.3.5.

The cutter will stop after the first contour has been cut and will come online again.

13. Raise the pinch rollers and manually remove the sheet.

14. Insert the next sheet into the cutter. Lower the pinch rollers.



ATTENTION: The second and any following sheet must be loaded in the cutter at the same position as the first sheet, with the same orientation. When in OPOS sheet mode, the cutter stores the distance between edges of the sheet and the first OPOS mark.



NOTE: Use easy orientation points to be able to quickly position the sheet. In the figure below, a rim of the base plate and the side of the pinch roller assembly are used to align the sheets.

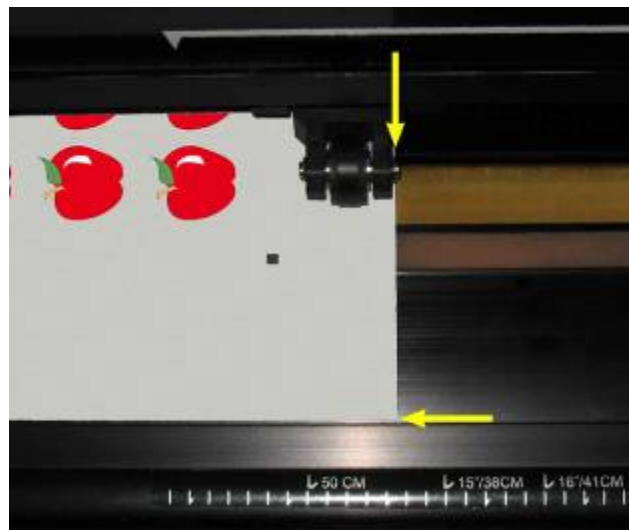

FIG 3-1
POSITION MEDIA FROM MULTIPLE SHEET

3.4.4 OPOS Barcode

The SummaCut cutters can also read a barcode. Certain RIP's can print a barcode together with the OPOS marks. This barcode can then be used to identify the job and retrieve the needed cut data automatically from the computer.

The complete procedure is normally started from the computer. The cutting software will usually have a button or a command called 'scan a barcode'. First make sure the media is loaded.

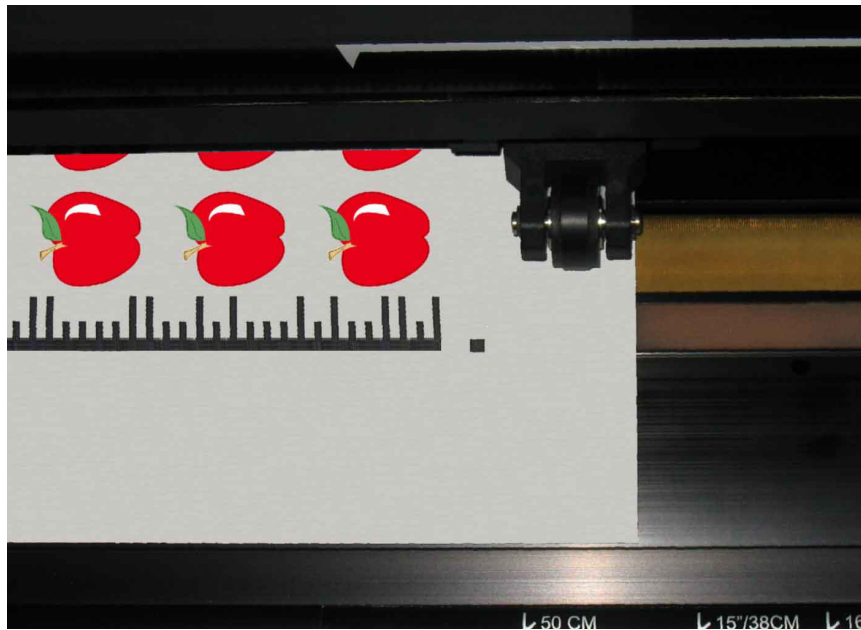

FIG 3-2
OPOS BARCODE JOB LOADED

Start the procedure from the computer or start from the touch screen.

To start from the touch screen:

1. Power on the cutter.

2. Press  .

'The cutter will prompt the user to put the tool under the barcode.'

3. Do so and press  .

The cutter will read the barcode and send this data to the computer.

The cutting software will then automatically send the correct cutting data to the cutter.

The cutter will start sensing the OPOS marks and cut out the job.

The OPOS sensor will now search whether another job was printed after the one that is just finished and will continue to contour-cut.

This will be repeated until all contour-cut jobs on the loaded roll are cut out.

3.5 Cutting through

3.5.1 Procedure

The cutting through functionality is focussed on cutting simple shapes (e.g. rectangles). It is mostly used in combination with contour cutting.

An interrupted cutting line (small 'bridges') makes sure the material remains together. When the job is finished the cut pieces can be torn out.

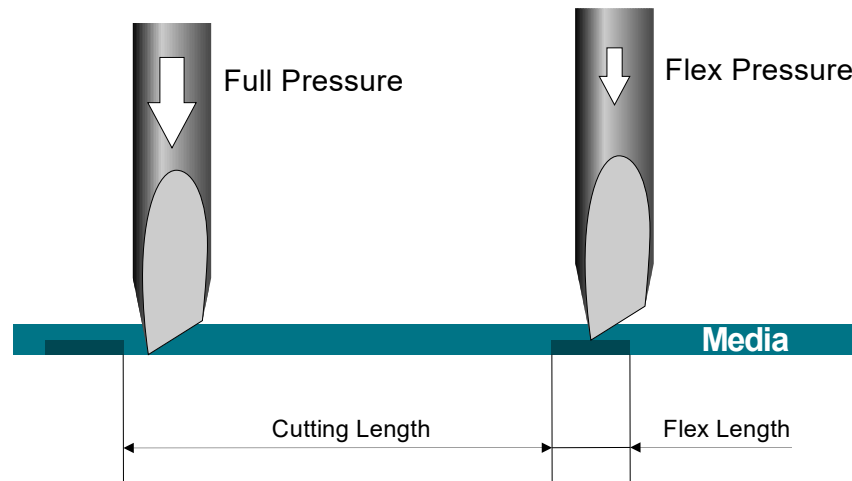

FIG 3-3
FLEXCUT PRINCIPLE

Some cutting software can recognize the difference between a contour line and a cut-through line. The software will send the data of the contour lines to the cutter first, activate FlexCut, panelling mode and vector sorting and then send the cutting through data to the cutter.



If the cutting software cannot do this, the user will have to send the data of the contour lines separately first, set the cutter manually in FlexCut mode and then send the data for cutting through.

Setting the parameters for cutting through the media:

1. Power on the cutter.

2. Press  .



'Knife pressure will appear on the LCD.'

3. Use  or  to scroll through the menu until 'FlexCut' is reached, press  .

'FlexCut' will appear on the LCD.'

4. Press  or  to choose the FlexCut parameter that needs to be changed.

The menu can scroll through full pressure, full pressure cut-length, Flex pressure and Flex pressure cut-length and FlexCut velocity.

5. Press  or  to change the value of the chosen parameter.

The value will change on the LCD.

6. Press  to confirm.

An asterisk will appear before the value, indicating it is now the selected setting.



ATTENTION: It is difficult to give recommended settings for FlexCut. Check section 3.5.2.2.

7.  can be pressed at any time during the settings of the parameters to check the result.

The cutter will cut out a pattern to check if the settings are usable.

8. Check if the result is satisfactory. If not, change one of the above parameters. Reducing the velocity can also improve the result.



NOTE: FlexCut parameters are always metric, regardless the value of the menu Units parameter (see section on 0)



ATTENTION: When cutting through, it is recommended that parallel lines are at least 1 cm (0.4") away from each other. Otherwise, while cutting the second line, the first line may come loose and cause trouble.



9. Press  to confirm.

10. Press  to leave the FlexCut menu.



'FlexCut' will appear on the LCD.

11. Use  or  to scroll through the menu until 'System setup' is reached, press .



'Actions' will appear on the LCD.

12. Use  or  to scroll through the menu until 'Settings' is reached, press .

'Velocity' will appear on the LCD.

13. Use  or  to scroll through the menu until 'Panels' is reached, press .

'ON' or 'OFF' will appear on the LCD, depending on whether panelling is already activated or not.

14. Press  or  to choose the Panel parameter panel size (unit of that value will be in cm).

The menu can scroll through on or off, panel size, recut and sorting.

15. Press  or  to change the panel size.

The value will change on the LCD.

16. Press  to confirm.

An asterisk will appear before the value, indicating it is now the selected setting.



ATTENTION: Recommended settings are: *Panels: ON; Panel size: 3-10 cm; recut: OFF sorting: ON.*

17. Press  twice.

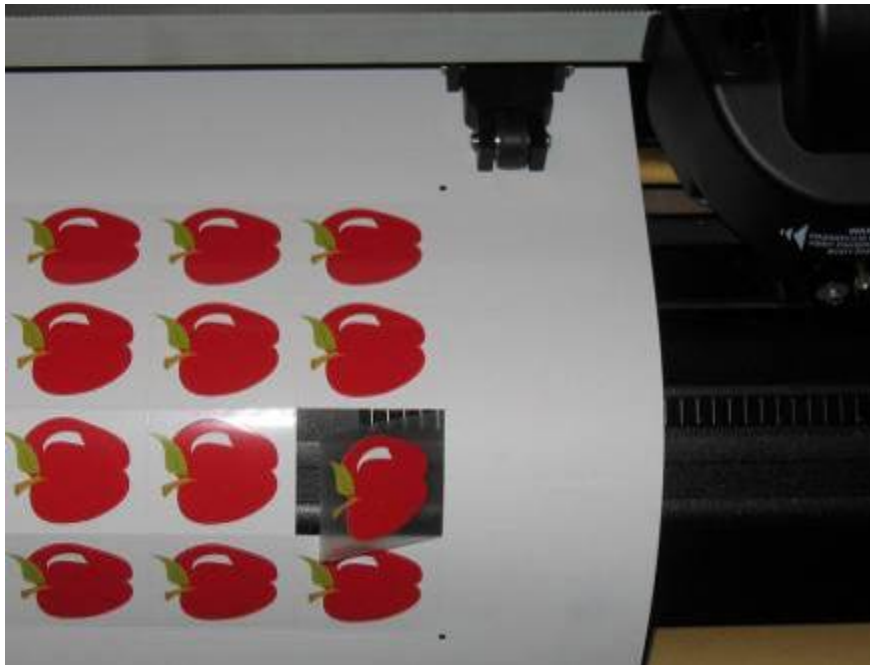

FIG 3-4
COMBINED CONTOUR CUT AND CUTTING THROUGH

3.5.2 Practical tips

3.5.2.1 Physical knife depth

Although very similar, there are two types of knife depth settings, one for normal cutting and one when FlexCut is used. What they have in common is that the knife is never turned out a lot.

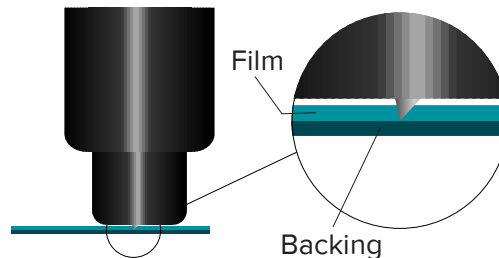

FIG 3-5
KNIFE DEPTH SETTING NORMAL CUTTING

For normal cutting the knife is turned out just a little bit more than the actual cutting depth. Turning out the knife much further results in unstable knife pressure and bad cut quality.

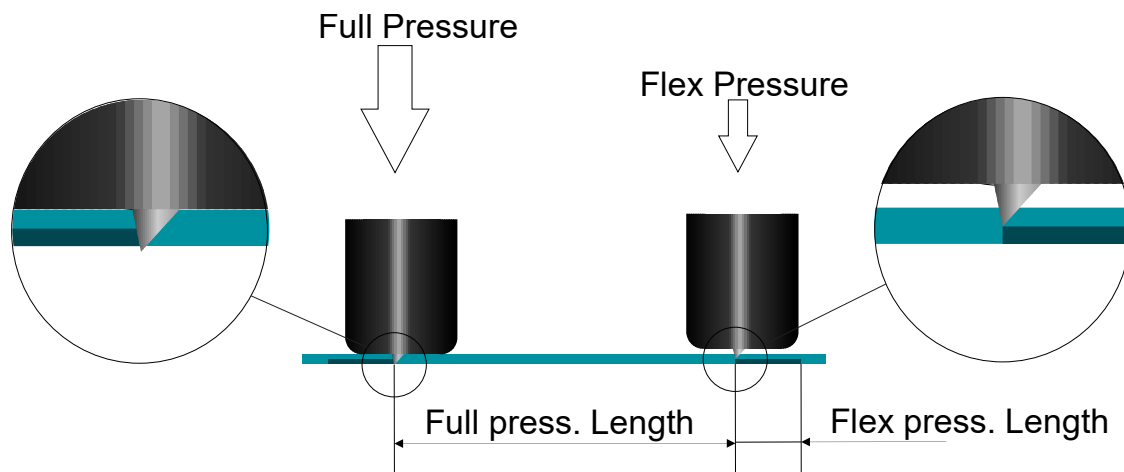

FIG 3-6
KNIFE DEPTH SETTING CUTTING THROUGH

When performing FlexCut the knife is turned out just enough to cut through the vinyl and backing. The decision to let the knife holder rest on the media at full pressure depends on the actual media you are using, if the media is prone to scratching, then make sure the bottom of the knife holder does not touch the media when using full pressure. If not, it is recommended to let the bottom of the knife holder touch the media at full pressure.

3.5.2.2 Values of the FlexCut parameters

Determining the values of the FlexCut parameters can be divided into two main steps. The first step is to determine the 'fixed' pressure values. Second step is determining empirically the length parameters.

➤ *Step 1*

First go to the knife pressure test as described in section 2.2.2. Determine the pressure need to cut completely through both vinyl and backing. Make sure the pressure is not set too high and the knife is not turned out too far.

After the needed pressure is determined, raise the knife a little bit to check if it still cuts completely through. If this is the case, do this again. If it does not cut completely through, then turn the knife out as it was.

Now lower the knife pressure a little bit to check if it still cuts completely through. If this is the case, lower it again a little bit. If it's not the case, set it at the previous value.

This is how the correct pressure to cut completely through the media is determined, as well as the correct amount the knife is turned out.



NOTE: Write down the pressure that was needed to cut completely through and do not change the physical knife depth anymore (unless the knife has worn down a little bit).

Now set the knife pressure correctly to cut just through the vinyl. Also write down this value.

➤ *Step 2*

Go to the FlexCut parameter setting menu as described in section 3.5.1. Set the full pressure parameter to the value that was needed to cut completely through the media (determined in step 1) and set the FlexCut pressure to the value needed to cut just through the vinyl.



NOTE: It is never recommended to use cutting speeds larger than 400 mm/s (16 ips) with cutting pressures above 170 gr. So, if the full pressure is larger, lower the FlexCut velocity.

Now go to the full pressure length parameter and set this to 10 mm. Go to the FlexCut pressure length and set this one to 0.8 mm. Perform a test. Check the bridges. If they are too large, perform a test with a lower value. If they are too small (or none-existent) then raise this value.

The FlexCut parameters are now set.

If these settings need to be adjusted, try with only changing the FlexCut pressure length. There is no need to adjust pressure settings, unless the knife wears down. In that case start again with step 1.



NOTE: It is not always easy to find the correct balance between cutting deep enough and making sure the pieces can be taken out easily and not cutting too deep, making sure the material keeps its strength while cutting. Sometimes this balance doesn't exist, meaning that this material can't be cut through with satisfactory result.

3.5.2.1 Material without a backing

Although FlexCut was designed for usage with standard vinyl (typical two layered material), it is also used with single layered material.

In this case the settings of the parameters is more difficult and requires more trial and error tests than calibrating FlexCut for normal vinyl.

The only parameter that can be determined easily is the full pressure.

The FlexCut pressure is very material depended. Plastics need a relative high FlexCut pressure. Fibrous material then needs relative lower FlexCut pressures.

The FlexCut pressure length of plastic materials is then relative short, while fibrous materials need longer 'bridges' to keep the material together in order to move it back and forth.

However, the principle is the same. The parameters need to be set this way the bridges are strong enough to be able to move the material back and forth. But the bridges need to be small enough, so they are practically invisible once the object is removed from the material.

A secondary help might be the adjustment of the panel size. With very weak material, lower the panel size.

Overall, the parameter setting for single layered material is difficult to do correctly.

4 Detailed Operation

4.1 Introduction

This section is a detailed list of all parameters that can be changed and tests that can be initiated from the control panel.

Section 1 and 2 of this manual describe in detail the most commonly used touch screen manipulation.

This section may be used as a reference for locating a certain parameter setting or test.

The less frequently used parameters are also explained in this section.

There are two menus: the main menu and the system setup menu.

4.2 Main Menu

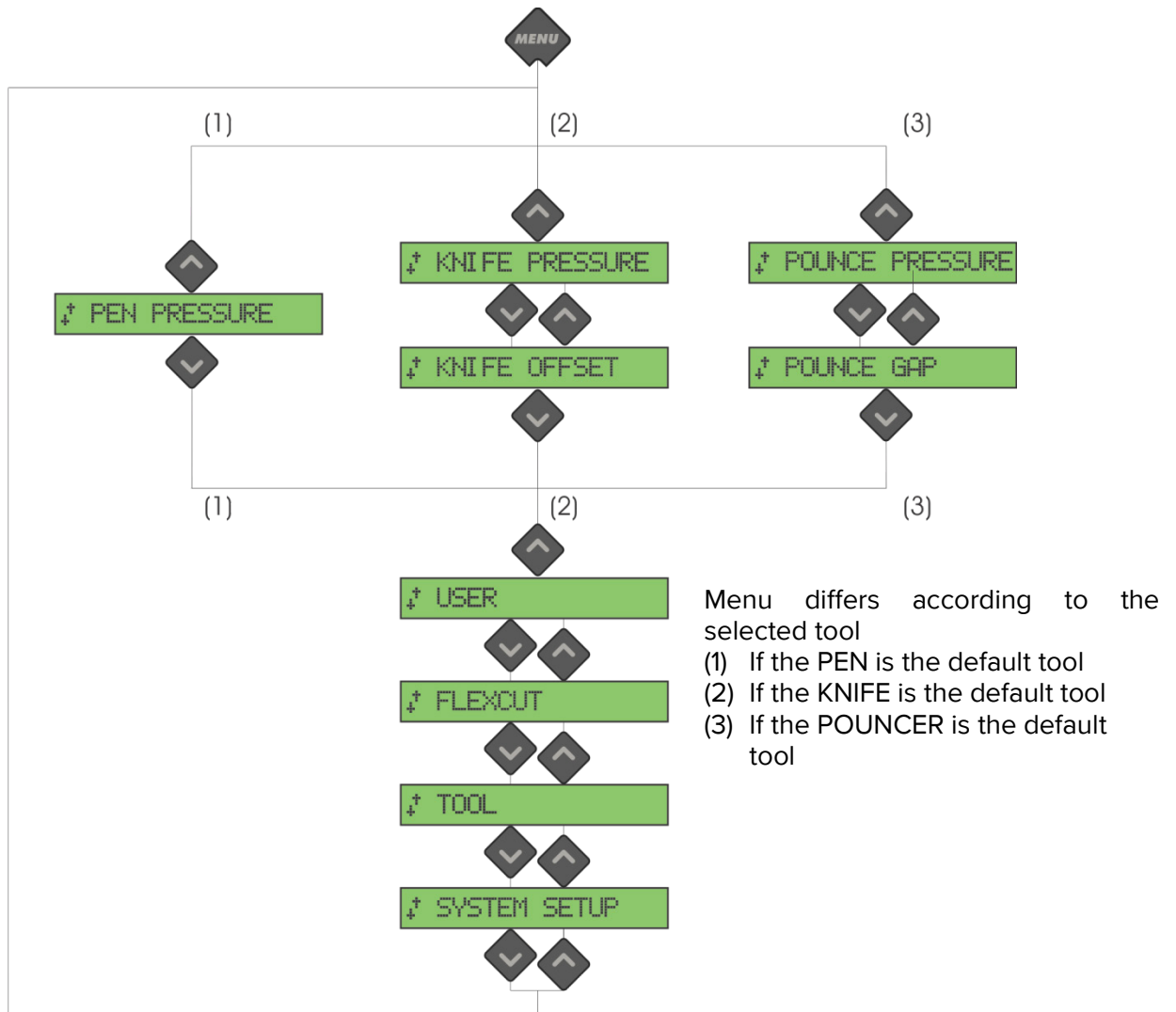

FIG 4-1
MAIN MENU

4.2.1 Pressure





Pressure is preceded by its tool name. This parameter is explained in section 2.2.2.

4.2.2 Knife offset

This parameter is explained in section 2.2.3

4.2.3 Pouncing Gap

The pouncing gap submenu is used to set or modify the distance between the pounced holes. The default pouncing gap value is 1 mm.

After pressing the  key, press the  or  jogging key until the desired pouncing gap is displayed on the LCD and press  to confirm. The value can be set between 1 mm and 50 mm.

4.2.4 User

The SummaCut cutters include 4 user configurations, all of which consist of the same parameters. Each configuration can have unique parameter settings. This allows the cutter to be quickly and easily reconfigured for different types of jobs or media. This parameter is explained in section 2.4.



4.2.5 FlexCut

The RESET instruction performs a complete reset of the cutter. Press the  key to execute a reset.

4.2.6 Tool

Different tools can be used on the SummaCut. A knife, a pen (without or with penholder) and a pouncing tool. If a tool is changed, then use this menu to set the machine to use this tool. This is explained in section 2.2.1.

4.2.7 System Setup

Press  to access the rest of the parameters and internal tests. This menu is split up into 4 submenu's. Scroll through those submenu's by using  or .

4.3 System Setup

4.3.1 Action menu

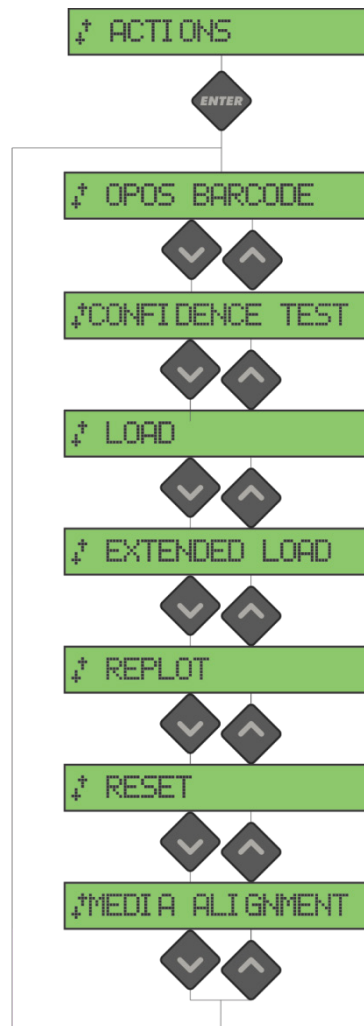



FIG 4-2
SETTING MENU

4.3.1.1 Opos barcode

Press  to start the barcode procedure (see section 3.4.4).

4.3.1.2 Confidence test

The confidence test performs a quick electrical and mechanical test of the cutter to make sure the cutter is fully operational. A media sheet of at least A3/B-size should be

used for this plot. Press  to start the test.

4.3.1.3 Load

This menu can be used when loading sheet material. During loading, the maximum material length can be set.

4.3.1.4 Extended Load

This parameter is explained in section 1.

4.3.1.5 Replot

The RECUT instruction recuts the last file, which was sent to the cutter (provided it fitted into the buffer). Press the  key to execute the instruction.

4.3.1.6 Reset

The RESET instruction performs a complete reset of the cutter. Press the  key to execute a reset.

4.3.1.7 Media alignment

Align load is a special loading procedure to register marks, so that pre-printed jobs can be contour-cut. The parameter is explained in section 3.3.5.

4.3.2 Setting menu

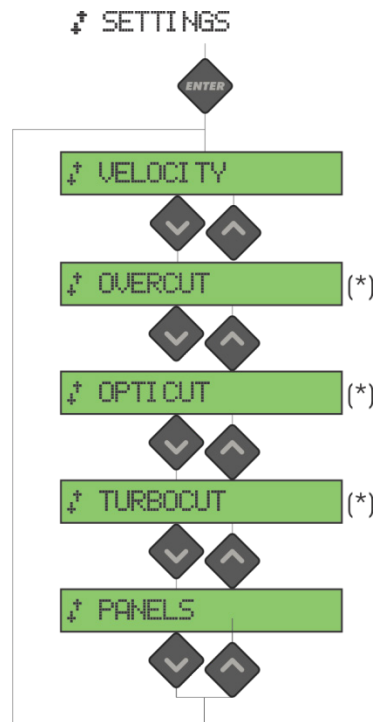

Menu differs according to the selected tool
 (*) only visible if the KNIFE is the default tool

FIG 4-3
SETTINGS MENU

4.3.2.1 Velocity

Velocity is the bundled parameter to change the speed of the tool/media. This parameter is explained in section 2.3.

4.3.2.2 Overcut

The Overcut submenu enables you to generate an overcut in order to facilitate weeding the cut. Each time the knife goes up or down, the cutter cuts a bit further. The overcut setting can be disabled (=0) or set to any value between 0(=off) and 10. One unit is about 0.1 mm or 0.004 ".

Summa

FIG 4-4
OVERCUT

Press . Use or to change the value. Press to confirm or to cancel. The default overcut is set to 1.



4.3.2.3 OptiCut



OptiCut increases the cutting quality in case the knife is worn out or not calibrated correctly.

Press . Use or to set OptiCut to ON or OFF. Press to confirm or to cancel. OptiCut is default set to OFF.

4.3.2.4 TurboCut

TurboCut increases throughput by speeding up the drag movement but without raising the overall speed of the plotter. The cutting time reduction is significant, especially when cutting small, detailed designs. However, some thicker materials might not cut well with this feature turned ON.

Press the TurboCut button, then use  or  to activate or deactivate TurboCut.

Press  to confirm or  to cancel.
TurboCut is default activated.

4.3.2.5 Panels

There are 4 specific parameters in the 'Panels' submenu:

1. *Panels*: This parameter switches panels on or off.
2. *Panel size*: This parameter determines the length of the panel.
3. *Panel replot*: This parameter determines if the design needs to be cut more than once, panel per panel. Panel replot is used for thick media and for media that is difficult to cut. The value of this parameter is disregarded if panelling is set to off. If this parameter is set at 0, the cutter will cut each panel only once. If it is set at 1, it will cut each panel twice.
4. *Sort vectors*: See the below paragraph.

Panelling is used for several different applications. Below are the typical settings for the most 2 common applications.

Cutting through: This is explained in section 0. Typical settings for the parameters are: Panels: ON; Panel size 5 – 10 cm; Panel replot: OFF; vector sorting: DIREC.

Tracking difficult media: Typical settings for the parameters are: Panels: ON; Panel size 3 – 10 cm; Panel replot: ON/OFF, depending on the thickness of the media. Vector sorting: DIREC./OFF, depending on the needed knife pressure and backing of the material.

Sort Vectors:

Sorting vectors is a submenu of the panel menu but because of its importance it is explained separately.

There are three options in this menu.

1. *Off*: When vector sorting is set to off, the cutter does no optimizing of the vectors. This is used when the intelligence of the cutter driver is preferred.
2. *Directional*: If set to directional, the vectors are optimized for the cutting direction (media movement). This is used when the cutting pressure needs to be set relatively high (for example during cutting through).
3. *Starting point*: This option optimizes the starting point for closed curves. This is used when the users notices the curves do not close as they should.

4.3.3 Calibration menu

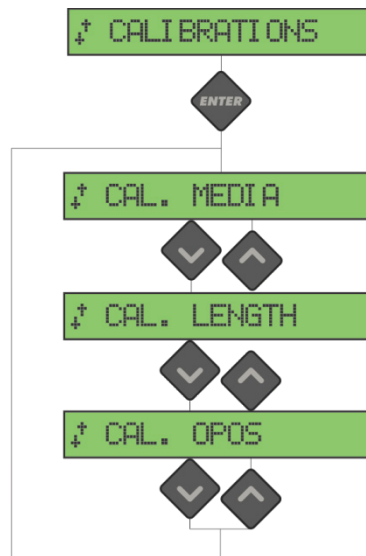

FIG 4-5
SETTINGS MENU

4.3.3.1 Cal. Media

Media calibration ensures that the sensor is able to recognize the marks. This is explained in section 3.2.2.

4.3.3.2 Cal. OPOS

This test calibrates the physical distance between the OPOS sensor and the knife tip. It is explained in section 3.2.1.

4.3.3.3 Calibrate XY

Length calibration allows the length of the cut lines to be adjusted within the specifications.

For instance, if a cut line should measure 100 mm exactly, the cutter can be adjusted for any discrepancy.

Calibration is explained in section 2.5.

4.3.4 Configuration menu

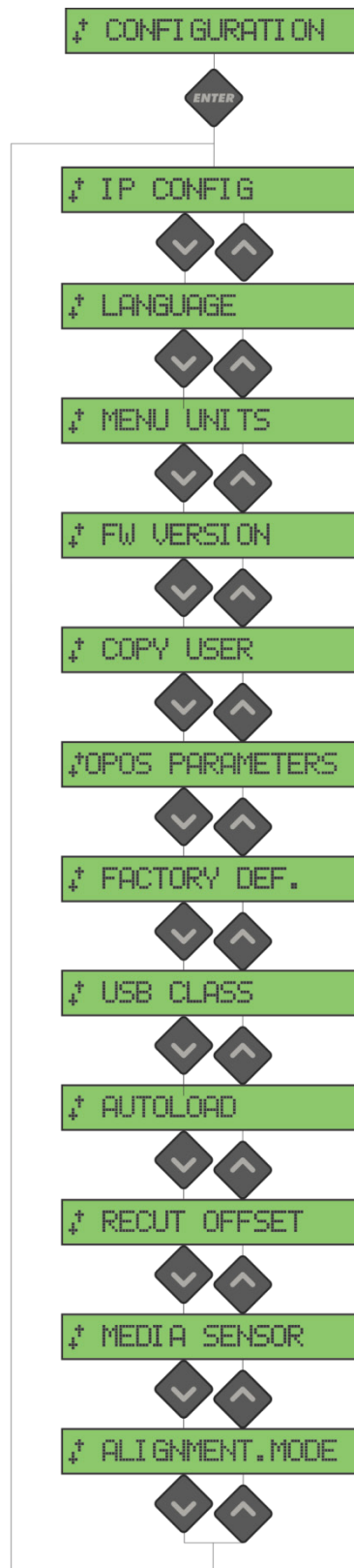
FIG 4-6
CONFIGURATION MENU





4.3.4.1 IP config

A couple of parameters need to be set when connecting a cutter to the Ethernet. This can be done in this menu. This is explained in section 1.5.2.

4.3.4.2 Language

This submenu is used to set or modify the dialogue language on the touch screen. When the machine is new, it asks the user to choose a language. If this setting was set to the wrong language, it can be changed with this option.





The information on the touchscreen can be displayed in English, French, German, Spanish, Italian, Polish or Dutch.

Press , then use  or  to set to the desired language. Press  to confirm or  to cancel.

The default language is chosen when the cutter is switched on for the first time.

4.3.4.3 Menu Units

The setting of these options determines whether the speed and size values are displayed in the metric measure system or in the ENG/US measure system.

Press , then use  or  to set to the desired measure system. Press  to confirm or  to cancel.

The panel units are chosen when the cutter is switched on for the first time.

4.3.4.4 FW version

Press the button to view information about the cutter's firmware revision. This information is often helpful to technicians when diagnosing problems over the telephone.

4.3.4.5 Copy User

This option copies all the settings of User 1 to the other 3 (user 2 to 4) by default.

4.3.4.6 OPOS Parameters

The setting of extra parameters has already been explained in previous sections.

Sheet mode

These settings are explained in section 3.4.3.

OPOS Panelling

These settings are explained in section 3.3.6

OPOS Origin

These settings are explained in section 3.4.1

4.3.4.7 Factory Def.





This option defaults all user parameters to factory default.

4.3.4.8 USB Class

USB class can be set to Summa USB port 1, Printer Uni (unidirectional), Printer Bidi (bidirectional), Summa USB port 2, Summa USB port 3, or Summa USB port 4.

Printer Uni and Printer Bidi are for use with printer adaptors with either network or wireless connection.

Because of the different USB id's, the computer can make a distinction between several cutters attached to it (maximum 4).

Press . Use  or  to change the USB Class. Press  to confirm or  to cancel. The default USB class mode is Summa USB port 1 (called standard on older machines - only this setting is compatible with older USB drivers).



ATTENTION: The minimum USB driver version required for attaching more than 1 cutter to the same computer is 6.2. The change in USB class only becomes active after rebooting the cutter.



ATTENTION: The USB id in the cutting software needs to be the same as the chosen USB id in the cutter. Each time a new USB is selected on the cutter and connected for the first time to the computer, the wizard will be started by Windows in order to install a driver.







ATTENTION: Cutters with firmware revisions lower than 19 do not have the possibility to assign an id to a USB port, so only one cutter can be connected to one computer via the USB.

4.3.4.9 Autoload

The Autoload option enables the user to change the vinyl unroll procedure. When autoload is activated, the cutter will automatically unroll the vinyl, when needed. When the autoload option is deactivated, the operator should manually unroll enough media before starting to cut. When autoload is set to ask, the cutter will pause as soon as the pinch rollers are put down. This gives the user the time to lower pinch roller pressure, if necessary.

The default setting is ON. Tracking is not guaranteed when autoload is set to OFF.

Press , then use  or  to activate or deactivate the autoload feature. Press  to confirm or  to cancel.





Autoload is activated by default.



ATTENTION: Tracking is not guaranteed when autoload is set to OFF.

4.3.4.10 Recut offset:





The **Recut offset** submenu is used to set or modify the distances between the jobs when making multiple recuts.

Press , then use  or  to change the baud rate. Press  to confirm or  to cancel. The default value is 40 mm.

4.3.4.11 Media Sensor

The media sensor detects whether media is loaded. It also detects the end of the media. The sensor prevents damage to the cutting strip and knife tip. The sensor can be activated or deactivated with this menu.

The cutter will stop during the loading procedure or while it is cutting as soon as the rear sensor detects the end of the media.

Press  , then use  or  to activate (ON) or deactivate (OFF). Press  to confirm or  to cancel.

The default setting for the media sensor is ON.

4.3.4.12 Alignment Mode

The OPOS settings are explained in detail in section 3, except for the Alignment mode. There are three additional alignment methods available on all SummaCut cutters: X-Alignment, XY-Alignment and XY-Adjustment.

These alignment methods can be used if the combination of mark colour – media colour cannot be read by the OPOS sensor.



These alignment methods require that the user manually registers marks, using the cutter's keypad. Most cutting software can put these marks around the printed graphic automatically.

X-Alignment compensates for errors in the media alignment, and therefore graphic rotation, by rotating the graphic's contour. This alignment method requires that the user specifies the origin as well as one point along the X-Axis. Distance parameters are not required. X-Alignment is the easiest alignment method.

XY-Alignment compensates for errors in graphic rotation and skew. Skew errors occur when the graphic's X and Y Axes are not perpendicular. This alignment method requires that the origin, as well as one point along both the X and Y Axes, are specified.

XY-Adjustment compensates for errors in graphic rotation, skew, and scale. Scale errors occur when the graphic's printed size is different from the graphic's original size, as created in the imaging software. X-Distance and Y-Distance parameters are required. These parameters define the distance between the origin and X-Axis point and between the origin and Y-Axis point. XY-Adjustment is the most accurate manual alignment method.

Press  . Use  or  to change the alignment method.

Press  to confirm or  to cancel. The default alignment method is OPOS.

5 Maintenance and Cleaning

5.1 Introduction

The SummaCut cutter range has a number of sliding surfaces, made of smooth metals and plastics. They are virtually friction-free and require no lubrication. They will, however, collect dust and lint that may affect the cutter's performance. Keep the cutter as clean as possible by using a dust cover. When necessary, clean the unit with a soft cloth, dampened with isopropyl alcohol or mild detergent. Do not use abrasives.

5.1.1 Cleaning the drive system

Over time, the sleeves of the drive drum may become clogged with accumulated residue from the media liner. This may cause the media to slip between the pinch rollers and the drive sleeves, resulting in decreasing traction.

Cleaning the drive system:

1. Make sure there is no media loaded in the cutter.
2. Switch off the cutter and disconnect the cutter from the mains. Raise the pinch rollers.
3. Put a pinch roller above the sleeve that needs to be cleaned. Make sure it is the outer left or the outer right pinch roller (otherwise there is not enough pressure).
4. Remove the backing from a piece of vinyl. Place the piece of vinyl between a pinch roller and a drive sleeve with the tacky side down. Lower the pinch roller.
5. Turn another yellow drive sleeve manually, so that the piece of vinyl is winding on the sleeve for at least one turn.
6. Then pull the piece of vinyl from underneath the pinch roller.
7. Repeat several times until all residue is removed from the drive sleeves.

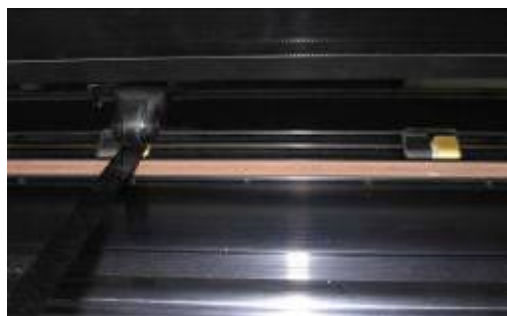

FIG 5-1
PLACEMENT OF VINYL STRIP

5.1.2 Cleaning the media sensor

Over time, the media sensor may become dirty with accumulated residue from the media. This may cause the cutter to malfunction.

Clean the media sensor by wiping them out with cotton swabs.

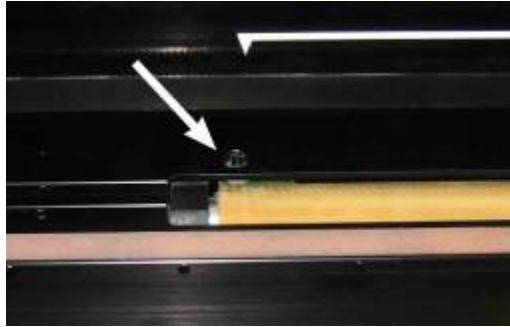

FIG 5-2
MEDIA SENSOR SUMMACUT CUTTERS

5.1.3 Cleaning the Y-Guide Rail

There are 2 V-shaped areas on the Y-guide rail on which the tools carriage slides from left to right. The areas are on the top and on the bottom of the front of the Y guiding. Although the shape of the Y-guide rail may differ from model to model, the areas are located in the same place at the top and bottom of the guiding. The figure below shows the top of the Y guiding.



FIG 5-3
SLIDING SURFACES ON Y=GUIDE RAIL

Over time, there may be some accumulated residue on these sliding surfaces and on the rollers of the tool carriage.

Cleaning the sliding surfaces of the Y-Guide rail:

1. Switch off the machine.
2. Take a soft cloth, dampened with isopropyl alcohol or mild detergent.
3. Clean the surfaces. When the tool carriage is in the way, push it gently to the left or right.

5.1.4 Changing the fuse



WARNING: Before changing the fuse, make sure the cutter is completely disconnected from its power source.



WARNING: For continued protection against risk of fire, replace only with the same type and rating of fuse: T2.0A, 250V SCHURTER SPT OR EQUIVALENT.

4. To remove the fuse (3), lightly pry the fuse holder release clip (2) in the direction opposite the power switch. The fuse holder will pop free.

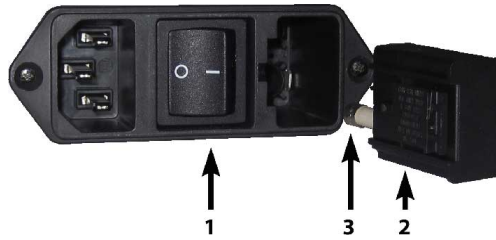

FIG 5-4
POWER ENTRY MODULE

5. Remove the fuse holder.
6. Pull the fuse from the holder.
7. Put the new fuse in the holder and clip the holder back into place.

6 Specs and General Information

6.1 Models

The SummaCut series are available in different sizes and different configurations. Depending on the region, certain sizes and or configurations may not be available. Also, the branding may be different. In this section, we refer to the basic model names D60, D75, D120, D140 and D160. Where known, it is marked if a specification is configuration depended.

The availability of certain models is region dependent.

6.2 Features List

6.2.1 Hardware

- Integrated roll feed system with media flanges.
- Fully adjustable media widths (not on the FX-Series).
- Stand with basket (Optional on D60 and D75; basket not standard on D140FX).
- Back Media sensor.
- OPOS
 - With barcode recognition.
 - OPOS X sensor automatically raised and lowered.

6.2.2 Interface

- 8-key control panel.
- 16-character liquid crystal display.
- English, Spanish, French, German, Italian, Dutch, Portuguese, Polish,
- Metric or English units.

6.2.3 Functionality

- Four separate user configurations stored in the non-volatile memory.
- Automatic media pull from roll.
- Concatenation and curve smoothing to obtain better cut quality.
- OptiCut drag-movement optimization.
- Overcut for easy weeding.
- FlexCut, Panelling, Vector Sorting.
- Multiple recut feature (up to 999).
- Flash EPROM's.

6.2.4 Software

- WinPlot
 - “Bridge” program to cut artwork created in other programs.
 - Windows 7, 8 and 10.
 - Connection by USB, serial, parallel or any printer port installed on operating system.
 - Connection by IP address.
 - Import of simple AI, EPS and DXF files.
 - Plug-in for CorelDraw 12 -> X7, for Adobe Illustrator CS -> CC.
 - Nesting, panelling, weeding box and cut by colour possibilities.
 - Integration of OPOS.
- MacSign™ Cut
 - “Bridge” program to cut artwork created in other programs.
 - Mac OS 9 & Mac OSX (10.2 or higher).
 - Import artworks from Illustrator, Freehand, Canvas, CorelDraw,...
 - Connection by USB.
 - Resizing positioning, mirroring, ...
 - Registration required.
- Summa Cutter Control
 - Program to control cutter parameters.
 - Utility to upgrade firmware.
 - Possibility to store user configurations on hard disk.
 - Windows 7, 8 and 10.
 - OPOS Barcode Server.

6.2.5 Cutter accessories and consumables delivered with cutter

The following accessories and consumables are available for your SummaCut cutter:

Manual and driver CD User's English, German, French, Spanish, Italian and Dutch	MD9045	Included
Power Supply Cables	region dependent	1x
Serial Cable	423-183	-
USB Cable	399-111	1x
Standard knife (set of 5x)	391-360	2 knives
Standard knife holder	391-332	1x
Sandblast knife (set of 5x)	391-358	-
Sandblast knife holder	391-363	-
Fibre tip pen (black) (set of 4)	MP06BK	1 pen
Rollerball pen (set of 4 :Red, Green, Blue, Yellow)	MP0646	-
Flanges for roll media (set of 2)	391-510	1 set
Manual cut-off razor blades (set of 10)	391-146	1 extra blade
Razor blade & holder	391-290	1x
Pouncing kit	391-595	-
Floor Stand D60(SE)	399-050	-
Floor Stand with Basket D60(SE)	399-075	-

TABLE 1:
ACCESSORIES AND CONSUMABLES

6.3 Technical Specification

6.3.1 Machine dimensions

	D60		D75		D120		D140		D160	
	mm	inch	mm	inch	mm	inch	mm	inch	mm	inch
Height	300	11.8	300	11.8	1120	44.1	1145	45.1	1145	45.1
Width	1000	39.4	1150	45.3	1600	63.0	1750	68.9	1980	77.9
Depth	350	13.8	350	13.8	680	26.8	680	26.8	680	26.8
Weight	15 kg	33 lbs	17 kg	37 lbs	42 kg	92 lbs	48 kg	106 lbs	54 kg	119 lbs

TABLE 2:
MACHINE DIMENSIONS

6.3.2 Shipping dimensions

	D60		D75		D120		D140		D160	
	mm	inch	mm	inch	mm	inch	mm	inch	mm	inch
Height	470	18.5	470	18.5	670	26.4	670	26.4	670	26.4
Width	1130	44.5	1280	50.4	1740	68.5	1880	74.0	2110	83.1
Depth	470	18.5	470	18.5	480	18.9	480	18.9	480	18.9
Weight	23 kg	51 lbs	27 kg	59 lbs	57 kg	125 lbs	69 kg	152 lbs	78 kg	172 lbs

TABLE 3:
SHIPPING DIMENSIONS

6.3.3 Media

	D60 ⁽⁴⁾		D75		D120		D140		D160	
	mm	inch	mm	inch	mm	inch	mm	inch	mm	inch
Media Width										
Minimum	70	2.8	70	2.8	120	4.7	180	7.1	180	7.1
Maximum	660	26.0	710	28.0	1260	49.6	1410	55.5	1635	64.4
Pinch rollers	2		2		3		4 (3 for FX)		4	
Max .working Width	600	23.6	750	29.5	1200	47.2	1350	53.1	1575	62
Oversized ⁽³⁾	630	24.8	780	30.7	1230	48.4	1380	54.3	1605	63.2
	mm					Inch				
Max. Working Length	50m					164ft.				
Minimum Margins⁽²⁾	25					1				
Front margin	18					0.7				
Rear margin										
Sensor on	42					1.7				
Sensor off	25					1				
Tracking⁽³⁾ performance	-8 m/26 feet max. within guaranteed specifications ⁽¹⁾ for media less than 762 mm (30" wide). -4m/13 feet max. within guaranteed specifications ⁽¹⁾ for media larger than 762 mm (30" wide).									
Thickness	0.05 to 0.25 / 0.8 mm with optional sandblast knife 0.002 to 0.01 / 0.03 inch with optional sandblast knife									

⁽¹⁾ Larger Media lengths can be handled, but compliance with specifications is not guaranteed (will be dependent on media type, media size and other parameters not mentioned here).

⁽²⁾ For positioning of the pinch rollers, these margins can be minimized using 'Oversized' mode⁽³⁾

⁽³⁾ In 'Oversized' mode the tracking performance is no longer guaranteed.

⁽⁴⁾ The FX Series have different media specifications as the pinch rollers can only be set in a limited number of positions.

For the D60FX: 6 positions:

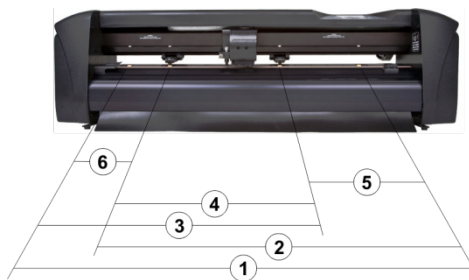

Position	Working area		Target media width (margin)	
	mm	= Inch	mm	Inch
1.	575	22.6	610 (18)	24 (0.7)
2.	470	18.5	500 (15)	20 (0.8)
3.	375	14.8	400 (13)	16 (0.6)
4.	270	10.6	297 (14)	12 (0.7)
5.	190	7.5	210 (15)	8.3 (0.4)
For scrap:				
6.*	95	3.7	115 (10)	4.5 (0.4)

* Media sensor should be disabled in order to use this position.

For the D140FX 9 positions:

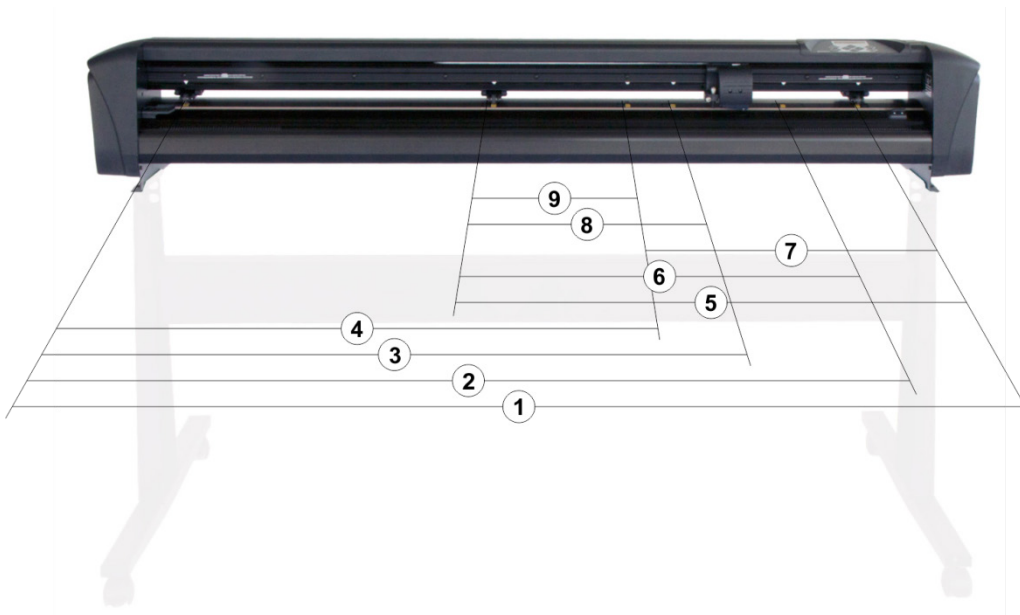

Position	Working area		Target media width (margin)	
	mm	Inch	mm	Inch
1.	1323	52.08	1372 (24)	54 (1.0)
2.	1172	46.18	1220 (23)	48 (0.9)
3.	954	37.55	1000 (23)	40 (1.2)
4.	864	34.01	914 (25)	36 (1.0)
5.	720	28.34	762 (21)	30 (0.8)
6.	570	22.44	610 (20)	24 (0.8)
7.	454	17.87	500 (23)	20 (1.1)
8.	350	13.77	400 (25)	16 (1.1)
9.	260	10.23	280 (10)	11 (0.4)
Minimum for scrap: (outer right position - not shown in picture)				
	84	3.3	105 (10)	4.1 (0.4)

* Media sensor should be disabled in order to use this position.

TABLE 4:
SUMMACUT MEDIA SPECIFICATIONS

6.3.4 Performance

Cutting specifications on 0.05 mm (0.002") wax-backed vinyl, total media thickness not greater than 0.25 mm (0.010").

Axial speed	50 to 800 mm/s	2 to 32 ips
Maximum Speed	Up to 1131 mm/s diagonal	Up to 44 ips diagonal
Default speed	700 mm/s	28 ips
Axial Acceleration	up to 2 G	
Max. Acceleration	up to 3 G diagonal	
Addressable resolution	0.025 mm, 0.1 mm	0.001", 0.005"
Default resolution	0.025 mm	0.001"
Mechanical resolution	0.0127 mm	0.0005"
Repeatability*	+/- 0.1mm	+/- 0.004"
Accuracy*	0.2% of move or 0.25 mm, whichever is greater**	0.2% of move or 0.010", whichever is greater**
Knife pressure	0 to 400 gr.	
Pen pressure	0 to 400 gr.	
Pouncing pressure	0 to 250 gr.	

*Valid within the guaranteed tracking length (see table 3). Not valid in 'Oversized' Mode.

**Excludes differences due to media expansion, stretching, etc.

TABLE 5:
SUMMACUT PERFORMANCES

6.3.5 Interface

Communication	Standard asynchronous RS-232-C and Universal Serial Bus .	
Serial I/O Port connector	DB-9P	
Mating connector	DB-9S	
Byte format	8 data bits, 2 stop bits, no parity	
Baud rate	57600, 38400, 19200, 9600, 4800, 2400 bps	
USB I/O Port connector	USB series "B" receptacle	
Mating connector	USB series "B" plug	
Ethernet I/O Port connector	RJ 45 Female connector	
Mating connector	RJ 45 Male connector	
Buffer Size	16 MB	

TABLE 6:
SUMMACUT INTERFACE SPECIFICATIONS

6.3.6 Firmware

Language	DM/PL, HP-GL (758x emulation), HP-GL/2
Supported character sets	Standard ASCII
Supported fonts	Sans serif (single stroke & medium)
ROM-based plots	Confidence plot, DIN plot

TABLE 7:
SUMMACUT FIRMWARE

6.3.7 Environmental

(Cutter without media)

Operating Temperature	15 to 35° C	59 to 95° F
Storage temperature	-30 to 70° C	-22 to 158° F
Relative humidity	35 - 75 %, non-condensing	35 - 75 %, non-condensing

TABLE 9:
SUMMACUT ENVIRONMENTAL SPECIFICATIONS



IMPORTANT HINT: The use of dimensionally stable media is an essential pre-requisite to obtain high cut quality. Additionally, media expansion or contraction may occur as a result of temperature variations. To improve the dimensional stability of media, let it stabilize to the current environmental conditions before use, for a minimum period of 24 hours.

6.3.8 Electrical

The power entry module detects the line voltage and switches automatically between 110V and 230V.

Main Supply: 48-62 Hz, single phase.

Nominal line	Min./Max. line	Fuse
110 V AC	88 - 132 V AC	T2.0A, 250V Schurter SPT or equivalent.
230 V AC	176 - 264 V AC	T2.0A, 250V Schurter SPT or equivalent.

TABLE 10:
SUMMACUT ELECTRICAL SPECIFICATIONS

Power requirements: 100-120 / 220-240 VAC, 50/60 Hz, 85 VA maximum



WARNING: For continued protection against risk of fire, replace only with the same type and rating of fuse: T2.0A, 250V SCHURTER SPT OR EQUIVALENT.

6.3.9 Certifications

Complies with ANSI/UL Standard 60950-1
and certified to CAN/CSA Standard C22.2 No 60950-1

FCC Class A

CE Marking (*)

Conforms to Directive 2012/19/EU of the European Parliament and of the Council on Waste Electrical and Electronic Equipment (WEEE)

Contains no substances, in a concentration above 0.1 % weight by weight, included on the candidate list according to article 59 (1, 10) of Regulation (EC) No 1907/2006 of the European Parliament and of the Council concerning the Registration, Evaluation, Authorisation and Restriction of Chemicals (REACH).

(*) CE Marking

Information Technology Equipment - Class A

Applicable Directives:

Directive 2014/35/EU of the European Parliament and of the Council
on electrical equipment, designed for use within certain voltage limits (LVD).

Directive 2014/30/EU of the European Parliament and of the Council
on electromagnetic compatibility (EMC).

Directive 2011/65/EU of the European Parliament and of the Council
on the restriction of the use of certain hazardous substances in electrical and electronic equipment (RoHS).

Harmonised Standards to which Conformity is declared:

EN 60950-1:2006 + A11:2009 + A12:2011 + A1:2010 + A2:2013 + AC:2011,
EN 55022:2010 + AC:2011,
EN 61000-3-2:2014,
EN 61000-3-3:2013,
EN 55024:2010,
EN 50581:2012.

6.4 Cutter accessories and consumables part numbers

The following chart contains descriptions and part numbers for the SummaCut accessories.

Part description	Part number	Picture
Manual and driver CD	MD9045	
Power cable (Regional differences, contact local dealer for exact part number)		
USB cable	399-111	
Serial cable	423-183	
Media flanges (set of 2)	391-510	
Standard drag knife holder	391-332	
Razor blade (set of 10)	391-146	
Drag knife 60° up to 0.6 mm cutting depth	391-231	
Standard drag knife (set of 5)	391-360	

<p>Sandblast drag knife (set of 5)</p>	<p>391-358</p>	
<p>Plotter pen (set of 4)</p>	<p>MP06BK</p>	
<p>Drag knife holder for sandblast knife</p>	<p>391-363</p>	
<p>Drag pouncing pin holder</p>	<p>391-595</p>	
<p>Pouncing pin</p>	<p>391-592</p>	
<p>Fuse</p>	<p>MF9003</p>	
<p>Cutting strip short</p>	<p>391-386</p>	
<p>Cutting strip long</p>	<p>400-565</p>	
<p>Pouncing strip</p>	<p>391-598</p>	

TABLE 11
SUMMACUT ACCESSORIES